

MTL4500 Series

isolating interface units



Instruction Manual

INM4500



CONTENTS

1	INTRODUCTION	1
1.1	General	1
1.2	The MTL4500 concept	1
2	MTL4500 SERIES DESCRIPTION	1
2.1	Standard backplanes	2
2.2	Customised backplanes	2
2.3	Accessories	2
3	INSTALLATION – PRECAUTIONS	2
3.1	General	2
3.2	Precautions	2
4	BACKPLANE INSTALLATION	2
4.1	Backplane mounting	2
4.2	Identification and tagging	4
4.3	Backplane earth rails	6
4.4	Backplane electrical connections	6
4.5	Backplanes – customised	8
4.6	Backplanes - module clip replacement	8
5	INSTALLATION – MODULES	8
5.1	Modules – pre-installation	9
5.2	Modules – installation	9
6	UNIT DESCRIPTIONS, SETTING-UP AND CONNECTIONS	11
6.1	Digital Input modules	12
6.1.1	MTL4501-SR - Fail-safe Switch/Proximity detector interface	13
6.1.2	MTL4510 & MTL4510B - Switch/Proximity detector interface	14
6.1.3	MTL4511 - Switch/Proximity detector interface	18
6.1.4	MTL4513 - Switch/Proximity detector interface	19
6.1.5	MTL4514 - Switch/Proximity detector interface	20
6.1.6	MTL4516 - Switch/Proximity detector interface	21
6.1.7	MTL4516C - Switch/Proximity detector interface	22
6.1.8	MTL4517 - Switch/Proximity detector interface	23
6.2	Digital Output modules	24
6.2.1	MTL4521/MTL4521L - Solenoid Alarm driver	24
6.2.2	MTL4523/MTL4523R - Solenoid Alarm driver	25
6.2.3	MTL4523L - Solenoid Alarm driver	26
6.2.4	MTL4524 - Solenoid Alarm driver	27
6.2.5	MTL4524S - Solenoid Alarm driver	28
6.2.6	MTL4525 - Solenoid Alarm driver	29
6.2.7	MTL4526 - Switch operated relay	30
6.3	Pulse and Vibration modules	31
6.3.1	MTL4531 - Vibration Transducer Interface	31
6.3.2	MTL4532 - Pulse Isolator	32
6.3.3	MTL4533 - Vibration Transducer Interface	34
6.4	Analogue Input modules	35
6.4.1	MTL4541/MTL4541S - Repeater Power Supply	35
6.4.2	MTL4541A/MTL4541AS - Repeater Power Supply	36
6.4.3	MTL4541B/MTL4541P - Repeater Power Supply	37
6.4.4	MTL4544/MTL4544S - Repeater Power Supply	38
6.4.5	MTL4544A/MTL4544AS - Repeater Power Supply	39
6.4.6	MTL4544B - Repeater Power Supply	40
6.4.7	MTL4544D - Repeater Power Supply	41

(continued on next page)

6.5	Analogue Output modules	42
6.5.1	MTL4546/MTL4546C/MTL4546Y - Isolating Driver	42
6.5.2	MTL4549/MTL4549C/MTL4549Y - Isolating Driver	43
6.6	Fire and Smoke Interface modules	44
6.6.1	MTL4561 - Fire and Smoke Detector Interface	44
6.7	Temperature Input module	45
6.7.1	MTL4575 - Temperature Converter	45
6.7.2	MTL4576-RTD - Temperature Converter	47
6.7.3	MTL4576-THC - Temperature Converter	48
6.8	General modules	49
6.8.1	MTL4599 - Dummy Isolator	49
6.8.2	MTL4599N - General purpose feedthrough module	49
6.9	PCS45/PCL45USB configurator for MTL temperature converters	50
7	FAULT FINDING AND ROUTINE MAINTENANCE	51
7.1	Maintenance precautions	51
7.2	Fault finding	51
7.3	Routine maintenance	51
8	BENCH TESTING MODULES	53
8.1	Digital Input (DI) modules	53
8.2	Digital Output (DO) modules	54
8.3	Analogue Input (AI) Modules	55
8.4	Analogue Output (AO) Modules	57
8.5	Testing the functioning of other modules	57
9	APPLICATIONS INVOLVING ZONE 2 AND/OR ZONE 22 HAZARDOUS AREAS	58
9.1	Enclosure	58

WARNING

This manual describes the use and installation of safety equipment. This equipment must be installed, operated and maintained only by trained competent personnel and in accordance with all appropriate international, national and local standard codes of practice and site regulations for intrinsically safe apparatus and in accordance with the instructions contained here.

ATEX

If the country of installation is governed by the Essential Health and Safety Requirements (Annex II) of the EU Directive 94/9/EC [the ATEX Directive - safety of apparatus] then MTL document INA4500 must be consulted before installation.

ELECTRICAL PARAMETERS (CSA)

Refer to the certification documentation (see below) for the electrical rating of these products.

CERTIFICATION DATA

The MTL web site <http://www.mtl-inst.com> contains product documentation regarding intrinsic safety certification for many locations around the world. Consult this data for information relevant to your local certifying authority.

REPAIR

These products MUST NOT be repaired. Faulty or damaged products must be replaced with an equivalent certified product.

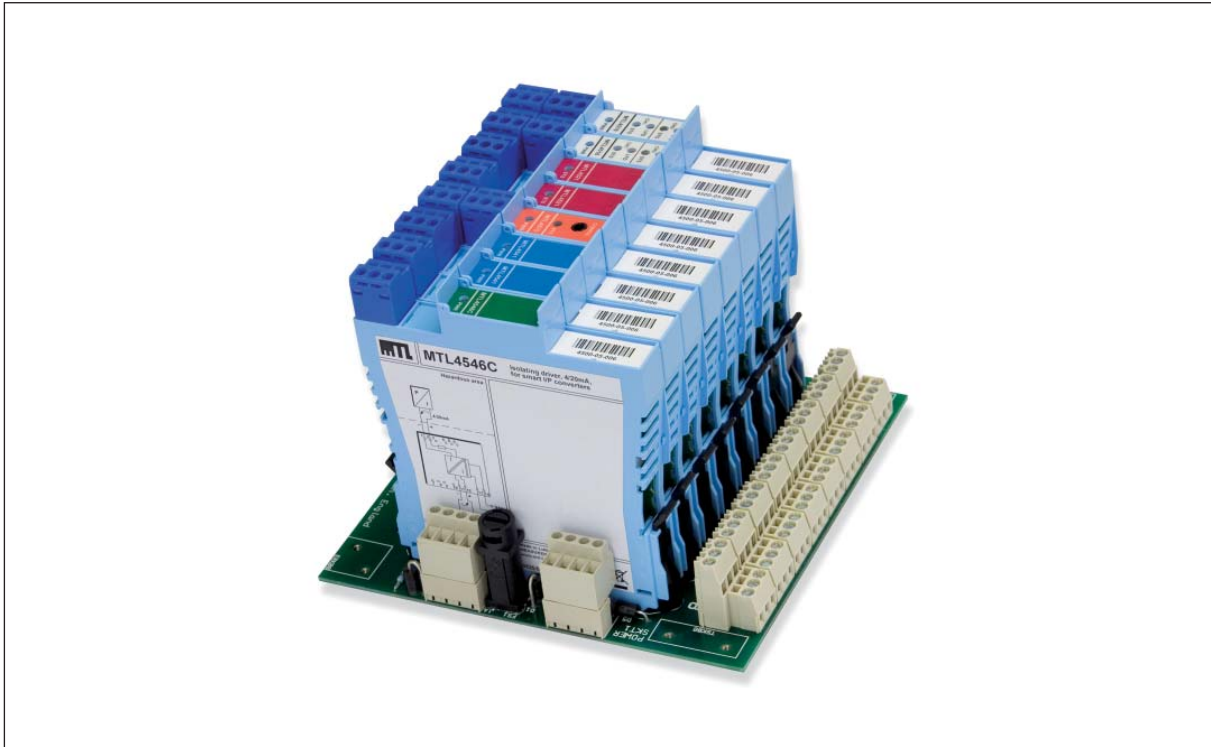

1 INTRODUCTION

1.1 General

This instruction manual describes the procedures for installing, connecting, checking and maintaining MTL4500 Series isolating interfaces and accessories.

The individual sections cover the following topics

- ◆ Section 2 describes the series and its accessories
- ◆ Section 3 precautions before and during installation
- ◆ Section 4 installing backplanes
- ◆ Section 5 installing modules
- ◆ Section 6 relevant technical data
- ◆ Section 7 fault-finding and maintenance
- ◆ Section 8 bench test procedures
- ◆ Section 9 hazardous-area application information

1.2 The MTL4500 concept

The MTL4500 Series of modules and accessories is designed for use with process connected systems. It consists of compact isolating interface modules mounted on backplanes, which carry safe-area signals and power supplies. Hazardous-area circuits are connected to the terminals on the modules. Backplanes can be integrated into a user's process system architecture or mounted in separate enclosures.

2 MTL4500 SERIES DESCRIPTION

Each module has a multi-pin connector in its base that plugs into a matching connector on the backplane. This connector carries all appropriate safe-area circuits and power supplies. Additional multiway connectors, located at the front of the module, accept the wiring from the hazardous-area circuits. All connectors are keyed so that connections cannot be made the 'wrong way round'.

Status LEDs and configuration ports (where appropriate) are located on the front of the modules for easy access and full dc isolation is provided between the input and output so that the modules are intrinsically safe without needing an earth.

2.1 Standard backplanes

MTL4500 series standard backplanes, with quick-release clip connectors, accommodate 4, 8, 16 or 24 modules. The backplane carries the safe-area signals and distributes dual-redundant 24V dc power supplies with three-point status monitoring. In applications where a number of 8- and 16-way backplanes are installed, the power supplies can be interconnected. Optional earth-rail kits are available for 8- and 16-way backplanes and tagging-strip kits are available for all backplanes.

2.2 Customised backplanes

If the backplane is to be mounted in a safe area (which is the most common type of application) then it does not need to be certified, because the hazardous area wiring connects to the I/O modules, *not the backplane*. This means that non-hazardous area backplanes can be produced easily by MTL, or the user, and can be designed to match exactly the size, shape, method of mounting, type of connector, pin assignments, etc, of a particular process system. Please contact MTL for further information.

When mounting the backplane in Zone 2/Div 2 hazardous areas the MTL web site should be consulted for documents detailing any approvals.

2.3 Accessories

Accessories are available that enable the user to mount standard MTL backplanes. These include surface-mounting kits, T-section and G-section DIN-rail mounting kits and end stops and a horizontal plate for mounting 24-way backplanes in 19-inch racks.

3 INSTALLATION – PRECAUTIONS

3.1 General

Please read this section before beginning to install backplanes, enclosures, modules etc.

3.2 Precautions

- a) Make sure that all installation work is carried out in accordance with all relevant local standards, codes of practice and site regulations.
- b) Check that the hazardous-area equipment complies with the descriptive system document.
- c) If in doubt, refer to the certificate/catalogue for clarification of any aspects of intrinsic safety, or contact MTL or your local MTL representative for assistance.
- d) Check that the interface unit(s) function(s) are correct for the application(s).
- e) When plugging modules into backplanes and hazardous-area connectors into modules, check the identification labels to make sure the items match correctly.

4 BACKPLANE INSTALLATION

4.1 Backplane mounting

See Table 4.1 for listings of the mounting methods and kits and accessories applicable to MTL standard backplanes and Figure 4.1 for dimensions and mounting centres.

4.1.1 Surface mounting – with SMS01 mounting kit

Refer to Figures 4.1 and 4.2.

- a) Drill mounting surface at centres A (Figure 4.1) and tap, or fit retaining nuts if required.
- b) Select the appropriate number of M4 x 20mm screws for the size of backplane (4 for a 4-way and 8-way, 6 for a 16-way and 8 for a 24-way backplane).
- c) Fit each M4 x 20mm screw (1) with a locking washer (2) and a plain washer (3) (Figure 4.2).
- d) Insert the screws through the backplane at each mounting centre A.
- e) Fit each with an M4 x 10mm spacer (5) and a retaining washer (6) (Figure 4.2).
- f) Attach the assemblies to the prepared surface using a suitable nut if the holes are not tapped.

Table 4.1: Backplanes, mounting kits and accessories

Backplane model number	Number of modules	Safe-area connections	Mounting Kits			Accessories		
			Surface	DIN-rail (T or G)	19-inch rack	Earth-rail kit	Tagging strip kit	Spare fuse pack
CPS04	4	Screw-clamp	SMS01	DMK01	–	–	–	FUS1.0ATE5
CPS08	8	Screw-clamp	SMS01	DMK01	–	ERK08	TSK08	FUS1.0ATE5
CPS16	16	Screw-clamp	SMS01	DMK01	–	ERK16	TSK16	FUS2.0ATE5
CPS24	24	Screw-clamp	SMS01	DMK01	HMP24	–	TSK24	FUS4.0ATE5

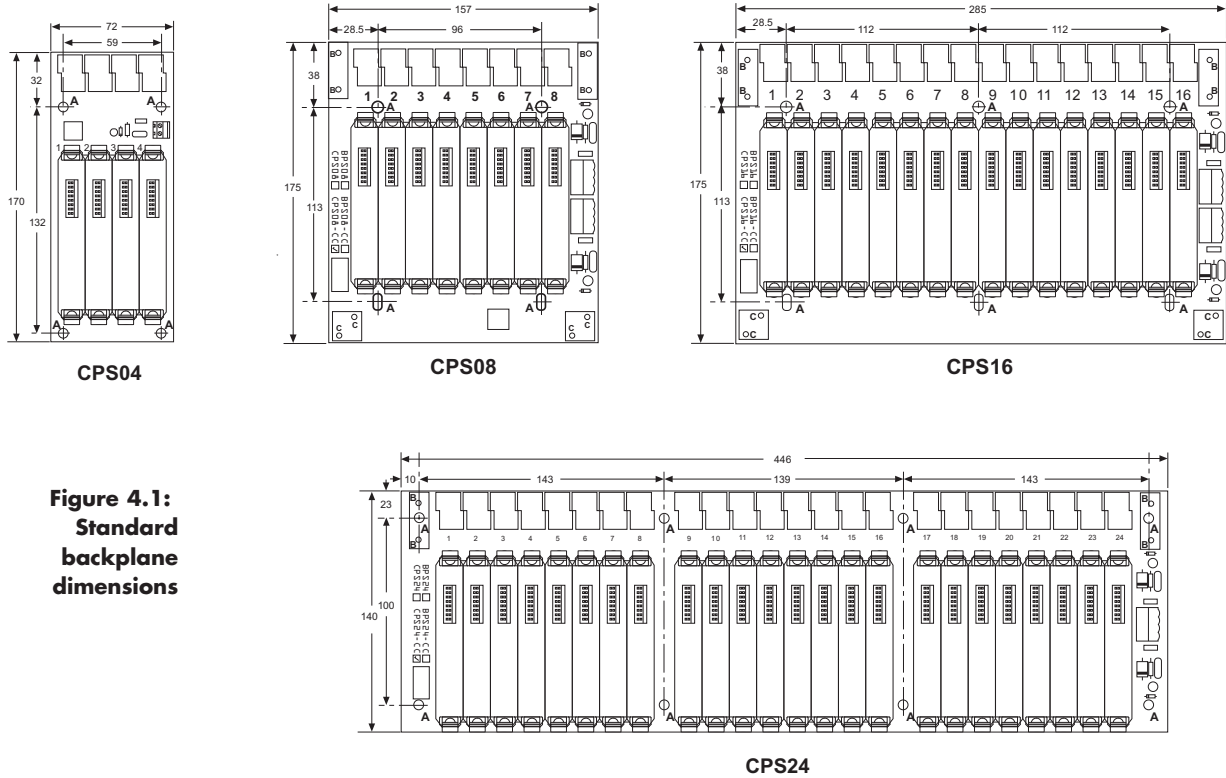

Figure 4.1: Standard backplane dimensions

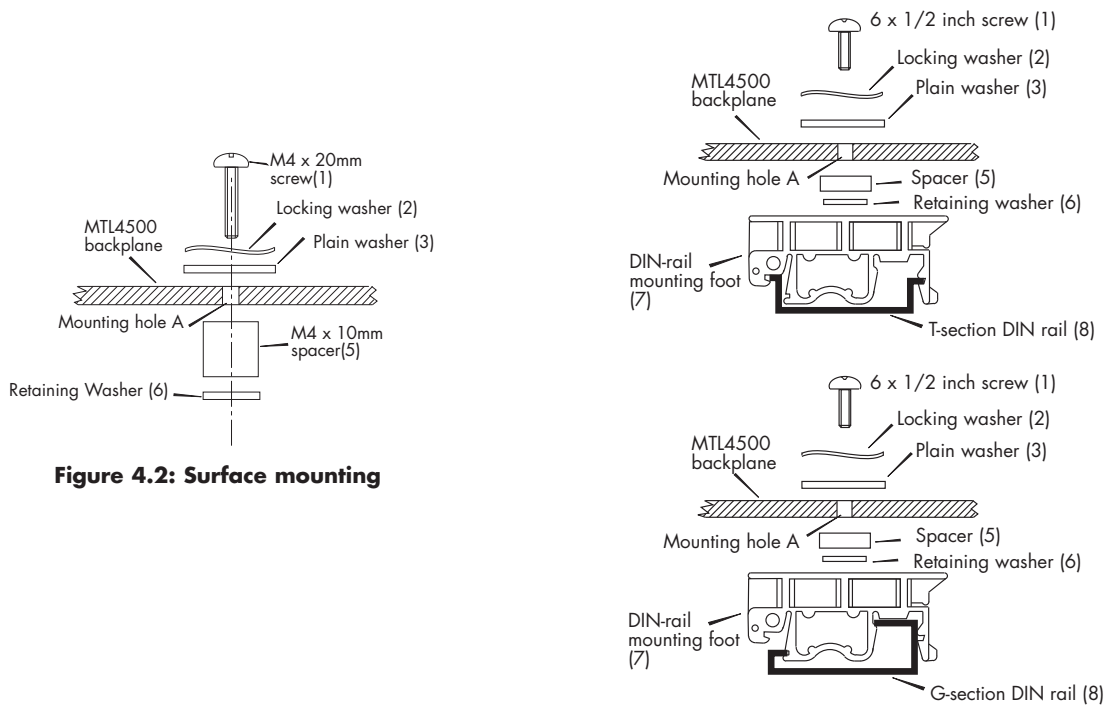

Figure 4.2: Surface mounting

Figure 4.3: Mounting a backplane onto DIN rail

4.1.2 T- or G-section DIN-rail mounting – with DMK01 mounting kit

See Figures 4.1 and 4.3.

- Cut two pieces of T- or G-section DIN-rail to the required length and fix them side-by-side with centres spaced appropriately – 132mm (CPS04), 113mm (CPS08/16) or 100mm (CPS24).
- With reference to Figure 4.3, clip the appropriate number of mounting feet (7) to the DIN rail (8) at centres 'A' (4 for each 4/8-way, 6 for each 16-way and 8 for each 24-way backplane) (Figure 4.3).
- Select the appropriate number of No. 6 x 1/2-inch screws (1) and fit each with a locking washer (2) and a plain washer (3) (Figure 4.3).
- Insert the assemblies through the mounting holes A on the backplane (Figures 4.1 and 4.3).
- Fit spacers (5), retaining them with the washers (6) (Figure 4.3).
- Locate the assemblies over the mounting feet and attach the screws (1) to the feet (Figure 4.3).

NOTE: For vertically orientated backplanes it is recommended that end stops with screw fixings are fitted on the DIN rails immediately below the lowest backplane fixing. This will avoid the chance of backplane slippage down the DIN rail.

4.1.3 19-inch rack mounting – CPS24 backplanes with HMP24 mounting plate

Figure 4.4:
19-inch rack
mounting

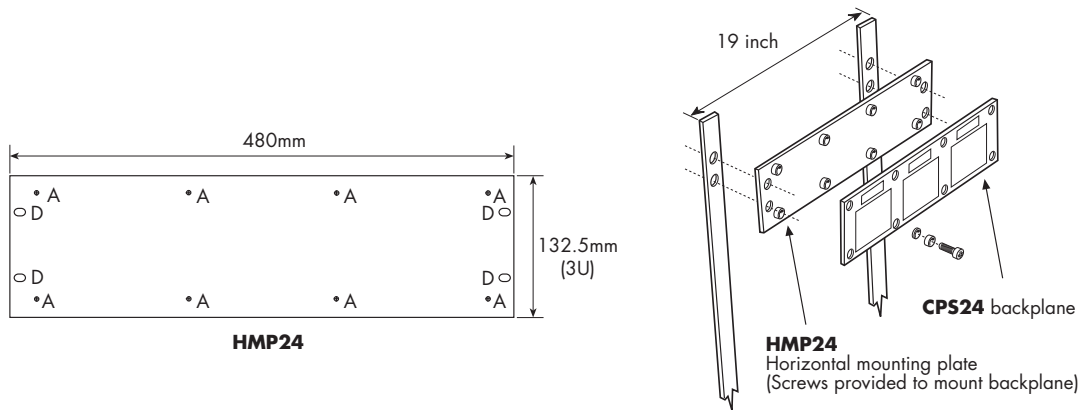

See Figure 4.4.

- Place an unloaded backplane onto the HMP24 mounting plate.
- Attach the backplane to the mounting plate at centres A with the eight M4 x 12mm screws provided.
- Attach the assembly to the 19-inch rack centres at D.

4.2 Identification and tagging

Backplane labelling facilities include marked areas for identifying backplanes, specific module locations and system connections (multiway backplanes only). Mounting holes for earth-rail and tagging-strip attachments are similarly marked

4.2.1 Backplane identification labels

- Attach a suitably marked label to the area marked BACKPLANE IDENT to identify an individual backplane (Figure 4.5).
- Attach suitably marked MPL01 module position labels to the areas marked MODULE IDENT (Figure 4.5).

Colour	Module no.	Function
White	MTL4501-SR MTL451x	Digital Inputs
Red	MTL452x	Digital Outputs
Blue	MTL4531/33	Vibration
Purple	MTL4532	Pulse
Blue	MTL4541x MTL4544x	Analogue Inputs
Green	MTL4546x MTL4549x	Analogue Outputs
Blue	MTL456x	Fire & Smoke
Orange	MTL4575 MTL4576	Temperature inputs
Grey	MTL4599	Dummy isolator

Table 4.2: MTL4500 front label colour coding

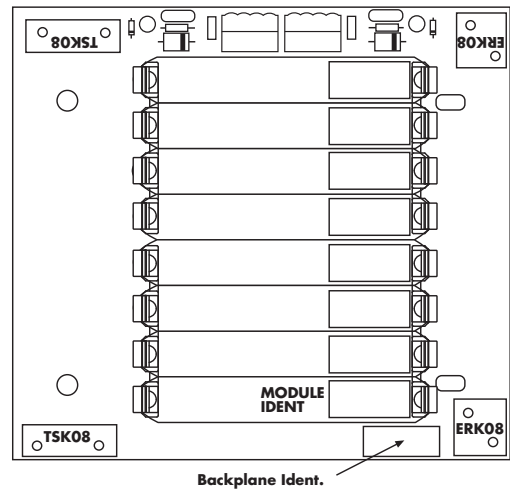

Figure 4.5: Locations for labels and attachments

4.2.2 Tagging strip mounting kit (TSK08, TSK16, TSK24)

See Figures 4.1, 4.6 and 4.7.

- Attach the tagging strip mounting posts (1) at backplane centres B (Figure 4.1) using two M3 x 12mm mounting screws (2) and washers (3) (Figure 4.6).
- Attach colour coding labels (4) to the tag label (5) (Figure 4.6). See Table 4.2 for suggested colour codes for individual modules.
- Mark the tag label (5) with the tag reference.
- Slide the tag label (5) into the plastic holder (6) and retain with a plastic rivet (9) (Figure 4.6).
- Attach the plastic retaining tie (7) with two plastic rivets (8) (Figure 4.6).
- Clip the tag strip holder (6) onto the mounting posts (1) by pushing it downwards (Figure 4.7).
- If required, swivel the tagging strip vertically (Figure 4.7)

**Figure 4.6:
Mounting a
tagging-strip
post**

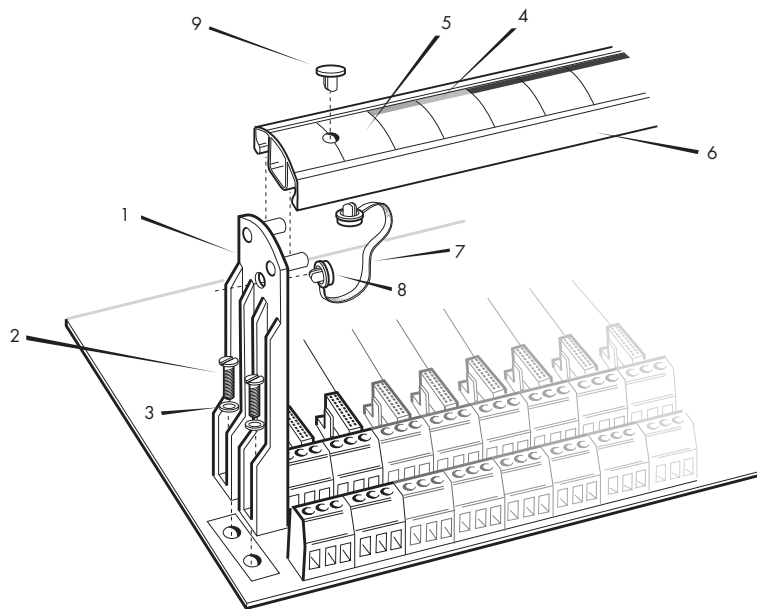

**Figure 4.7:
Attaching and
swivelling a
tagging-strip**

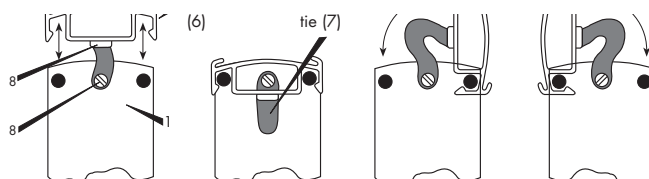

4.3 Backplane earth rails

Optional earth rails are available for 8- and 16-way backplanes (kits ERK08 and ERK16 respectively). Cable screens from hazardous-area circuits, or spare pairs from a multicore cable, can be connected to the terminals on the earth rails, which are mounted on the backplane at about the same height as the front of the modules, close to the hazardous-area connectors. Proceed as follows.

4.3.1 Earth rail kit (ERK08 and ERK16)

See Figures 4.1 and 4.8.

Figure 4.8:
Earth rail post
kit details

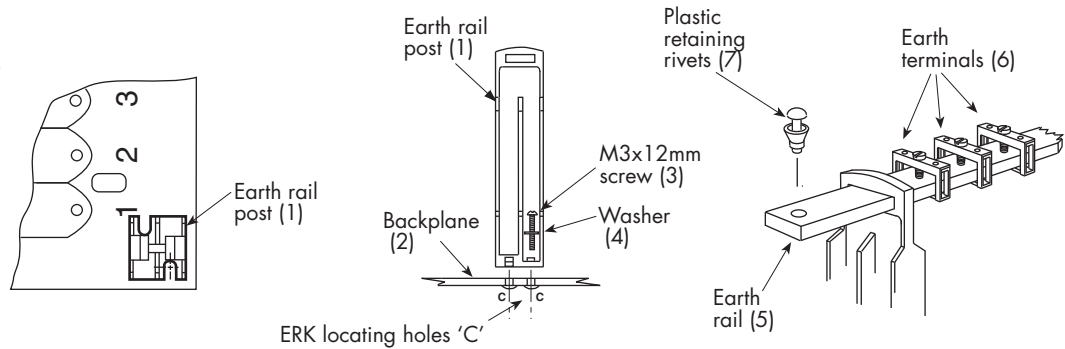

- Locate the earth rail mounting posts (1) at backplane centres C (Figures 4.1 and 4.8).
- Attach the mounting posts (1) with M3 x 12 screws (3) and washers (4).
- Slide the earth rail (5) through the slots in the of the mounting posts (1).
- Fit the earth terminal(s) (6) on the rail (5).
- Attach plastic retaining rivets (7) to each end of the earth rail (5).

4.4 Backplane electrical connections

Safe-area circuit connections are made to the backplane by fixed screw-clamp terminals. Power supply connections are also made to the backplanes via *pluggable* screw-terminal connectors.

For optimum EMC performance, cables from local power supplies should not exceed 10m in length. See section 4.4.2 for details, section 4.4.3 for a procedure to interconnect power supplies on multiple 8- and 16-way backplanes, and section 4.4.4 for details of connecting power supplies on 24-way backplanes.

4.4.1 Making connections

- Trim back the insulation of conductors by 12mm.
- Check the terminal assignments shown in section 6 or on the side label of the unit.
- Insert conductors according to the terminal assignments and tighten screws.

If the wires are to be fitted with crimp ferrules, the following is a list of those recommended with required trim lengths for each:

Plug type	Entry	Wire size (mm ²)	Metal tube length (mm)	Trim length	Recommended ferrules
Signal	Single	0.75	12	14	Weidmuller 902591
Signal	Single	1.0	12	14	Cembre PKC112
Signal	Single	1.0	12	14	Phoenix Contact AI 1-12 RD (3200674)
Signal	Single	1.5	12	14	Cembre PKE1518†
Signal	Single	2.5	12	14	Cembre PKE2518†
Power	Twin	2x0.75	10	12	Cembre PKET7510
Power	Twin	2x0.75	10	12	AMP (non-preferred) 966144-5
Power	Twin	2x1.0	10	12	Phoenix Contact AI-TWIN 2X 1-10 RD
Power	Single	0.75	10	12	AMP 966067-0
Power	Single	1.0	10	12	Phoenix Contact AI 1-10 RD

† These ferrules with 18mm length metal tubes should be cut to 12mm after crimping

Note: Smaller section wire than that stated can often be successfully used if the crimping is good.

Crimp tool: Phoenix Contact Crimpfox UD6 part number 1204436

Figure 4.9:
Terminal pin assignments

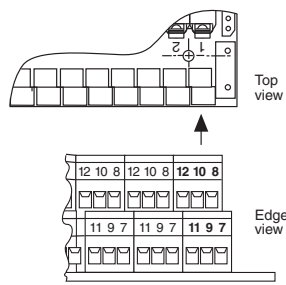

Figure 4.12:
"Ring main"
wiring for
DC power

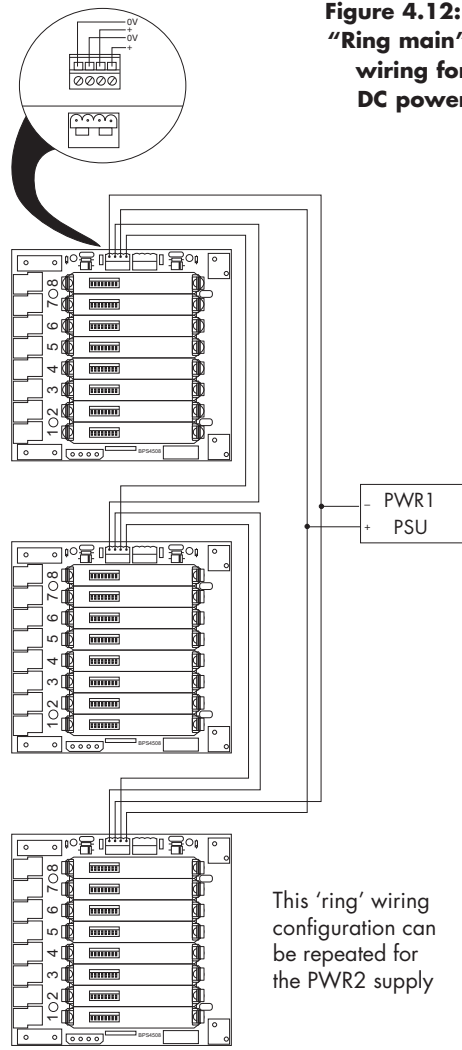

Figure 4.10:
PSU connections
8- & 16-way

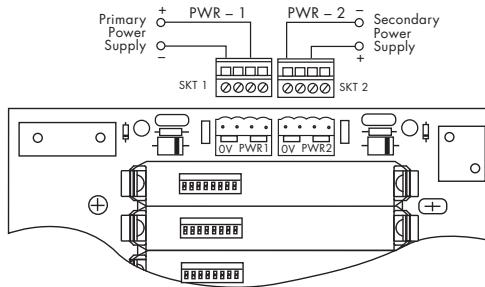
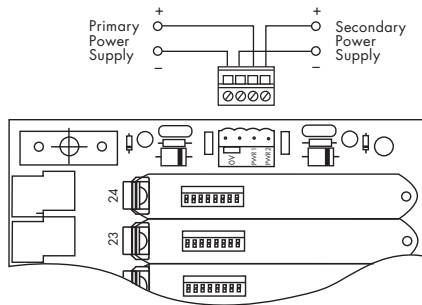

Figure 4.11:
PSU connections
24-way



4.4.2 Safe-area - signal connections

Each module position is provided with a 6-way split-level terminal block for safe-area signals. The six terminals reproduce the module terminals numbered 7 to 12 as shown in Figure 4.9.

- Make the appropriate connections to the terminal block in accordance with the pin assignment numbers reproduced in Figure 4.9.
- Wire entry for each terminal is from the side of the block.
- The maximum permissible wire gauge is 2.5mm² (14 AWG).

4.4.3 Safe area - discrete power supply connections (8- and 16-way backplanes)

Dual-redundant 24V DC power supplies can be connected to each backplane using plug-in connectors. The supplies are connected in parallel, through diodes, and bussed by the backplanes to individual isolators. LEDs on the backplane will light to show that the two independent supplies are operational. The diodes between the two supplies means that the one with the higher voltage is used at any given moment, but provide automatic switchover of supplies if one source fails.

- Connect each of the two 21V to 35V dc power supply connectors to the independent supply sources according to the terminal assignments shown in Figure 4.10. The maximum permissible wire size is 2.5mm² (14 AWG).
- Plug the power supply connectors into the base connectors on the backplanes.
- The fuses on the backplanes are rated as follows:-

8-way: 1A (FUS1.0ATE5) 16-way: 2A (FUS2.0ATE5)

4.4.4 Interconnecting power supplies for multiple 8- and 16-way backplanes

Power supplies for 8- and 16-way backplanes can be interconnected in the form of a ring. This can reduce wiring and also permits individual backplanes to be taken out of service without affecting supplies to the other backplanes. More than one backplane can be removed, provided that they are immediate neighbours and ensures that other backplanes are not left without an active supply. The connection method is shown in Figure 4.12.

Note: a mixture of 8- and 16-way backplanes can be interconnected, provided that the maximum circuit current does not exceed 12A. Wire sizes up to 2.5mm² (14 AWG) can be used and should be chosen after calculating the voltage drop for the current load.

4.4.5 Safe area – discrete power supply connections (24-way backplanes)

Dual-redundant 24V DC power supplies can be connected to each backplane using plug-in connectors. The supplies are connected in parallel, through diodes on the backplane, and bussed to individual isolators. LEDs on the backplane will light to show that the two independent supplies are operational. The diodes between the two supplies means that the one with the higher voltage is used at any given moment, but provide automatic switchover of supplies if one source fails.

- a) Connect the power supply cables to the connector according to the pin assignments shown in Figure 4.11. The maximum permissible wire size is 2.5mm² (14 AWG).
- b) Plug the power supply connector into the base connector on the backplane.
- c) The rating of the fuse is:– 24-way: 4.0A (FUS4.0ATE5 fuse kit)

4.5 Backplanes – customised

For information about installing customised backplanes (whether supplied by MTL or by a third party), see the separate instructions provided with the units.

4.6 Backplanes - module clip replacement

Any broken module retaining clips must be replaced to maintain safe operation. Clips are constructed in a moulded strip of four and are secured to the backplane with plastic rivets. Spare sets are available as part number SCK45 which contains 10 strips of four clips plus 40 rivets.

4.6.1 Changing a damaged strip

- a) Identify the strip of four clips that includes the damaged clip and remove the modules that are retained by that strip.
- b) Using a small pointed tool, such as a small screwdriver, push out from the underside the four rivets securing the clips and remove the strip.
- c) Fit a new strip of four clips and insert new rivets, pressing them in fully. Do not reuse the existing rivets as they will be deformed by previous use.



Figure 4.13: Module clips and rivets

5 INSTALLATION – MODULES

Important

- ◆ Work should be carried out in accordance with all relevant local standards, codes of practice and site regulations.
- ◆ Check that the hazardous-area equipment complies with the descriptive system document.
- ◆ Refer to the certificate/catalogue for clarification of any aspects of intrinsic safety or contact MTL or your local MTL representative for assistance.
- ◆ When installing MTL4500 Series isolators it is essential to make sure that intrinsically safe and non-intrinsically safe wiring is segregated, as required by a nationally accepted authority or as described in EN 60079-14, ISA RP 12.6 or DIN VDE-165.
- ◆ Make sure the correct hazardous-area connector (field-wiring plug) is plugged into the corresponding isolator. It is recommended that the connector is identified by the same tag number as the matching isolator.

5.1 Modules – pre-installation

5.1.1 Switch settings for operating conditions

Some modules have operating conditions, such as Line-Fault Detection (LFD), Phase Reversal, etc., that can be established by the setting of switches on the unit. The subminiature switches are accessible through an aperture on the side of the module (see Figure 5.1) and can be set in the required positions with, for example, the blade of a small screwdriver.

Figure 5.1:
Location
of switches

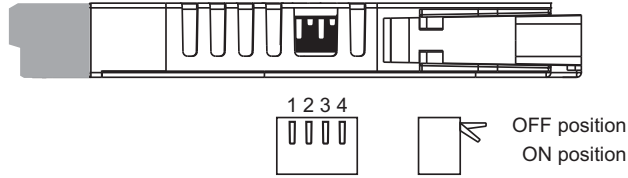

The switch setting options are always indicated on the side label of the module, but the user may also consult the individual module information in Section 6 of this manual for details.

5.1.1 Relay outputs

Reactive loads on all units with relays should be adequately suppressed. To achieve maximum contact life, a minimum switching current of 10mA at $\geq 5V$ is recommended.

5.1.2 Earth leakage detection

An MTL4220 earth leakage detector can be used with a number of MTL4500 Series units to detect hazardous-area earth faults which can then be rectified without needing to shut down the loop ('no-fail' operation).

Note: If the hazardous area signal plug fitted does not have a screw terminal in position 3 then part number 'HAZ1-3' can be ordered and fitted to use this function.

5.1.3 Ambient temperature considerations

Ambient temperature limits for unenclosed MTL4500 Series isolators are from $-20^{\circ}C$ to $+60^{\circ}C$ with units close-packed.

5.2 Modules – installation

5.2.1 Signal conductors

The removable hazardous area signal plugs are located on the front of the module. They are fitted with screw clamp terminals and mechanically keyed to fit only in the correct position. Note that the conductors should be between 14 and 24 AWG (1.6 and 0.5mm dia) in size.

Figure 5.2:
Hazardous-area
plug (blue)

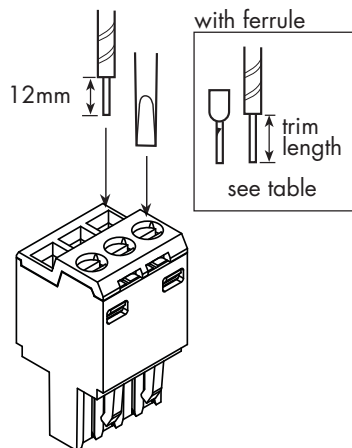

5.2.2 Electrical connections

See Figure 5.2 and also Section 4.4.1 on page 6 for details on choosing ferrules.

- Trim back the insulation for solid conductors by 12mm (or to the length shown in the table on page 6 when fitting a ferrule for stranded wire).
- Check the module terminal assignments - shown in section 6 or on the side label of the unit.
- Insert conductors according to the terminal assignments and tighten screws.

Note: Smaller section wire than that stated can be used successfully if care is taken to ensure that the wire is properly secured after crimping the ferrule.

5.2.3 Finishing

Wire up individual isolators in accordance with wiring schedules. Segregate hazardous- and safe-area wiring into separate trunking or looms wherever possible to avoid errors and maintain a tidy installation.

Use an MTL4599 dummy isolator to provide termination and earthing for unused cores from the

hazardous area.

5.2.4 Module mounting and removal

Check for the correct orientation of the module then locate it between the latching clips. Press the module straight onto the backplane. See Figure 5.3.

To remove the module, unclip the latch nearest the CE mark shown on the module label and rotate the module away from this latch. When the module is unplugged from the power connector, move the module clear of the other latch and remove it. See Figure 5.4.

Figure 5.3:
Mounting a module
onto a backplane

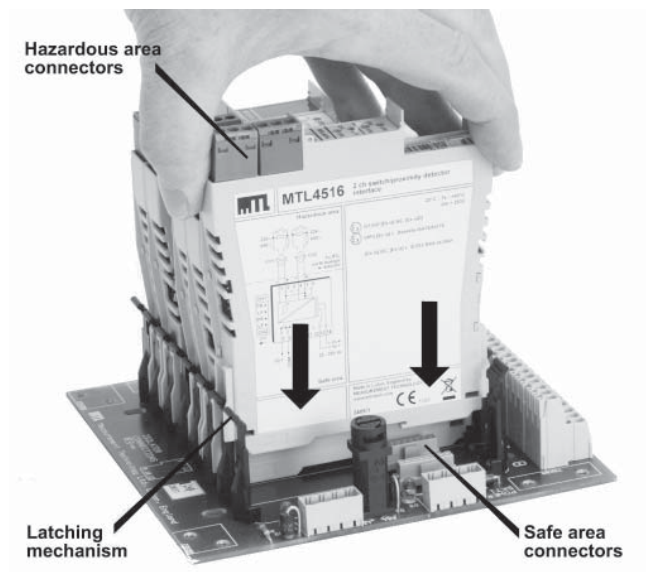
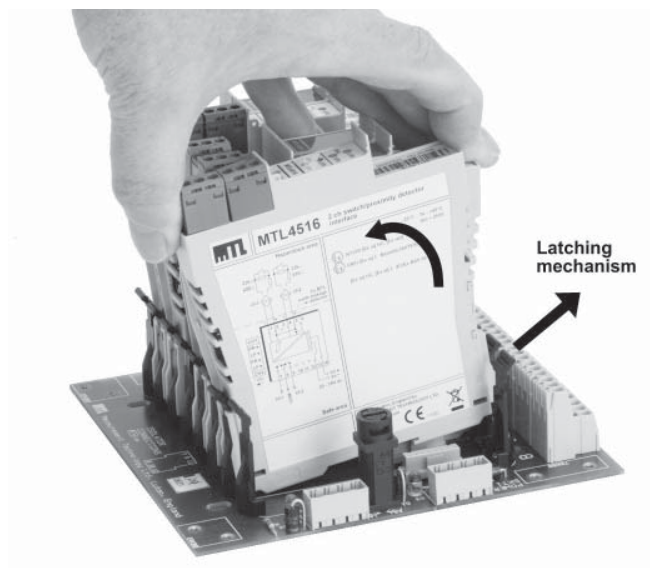

Figure 5.4:
Removing a module
from a backplane



6 UNIT DESCRIPTIONS, SETTING-UP AND CONNECTIONS

This section describes the function (briefly), the setting-up procedure and the wiring connections for each MTL4500 Series unit. For a fuller functional description and a detailed technical specification, refer to the individual datasheets, which can be found on the MTL web site at <http://www.mtl-inst.com> or in the current MTL IS catalogue. If a fault is suspected, first check that the power LED is lit (not applicable to loop-powered devices). If necessary, check that all signal and power plugs are properly inserted, that no wires are loose and that the unit is mounted correctly. If operation is still suspect, the unit should be replaced with a servicable unit.

There are no replaceable parts insided MTL4500 Series units, so any that appear to be inoperative should be returned to the manufacturer/supplier for repair or replacement.

WARNING

When disconnecting units for maintenance purposes, take care to segregate hazardous and safe-area cables.

- **Short circuit hazardous-area cable cores to an IS earth or insulate and secure the ends.**
- **Insulate and secure safe-area cables.**

If testing a unit 'in situ' note that the test equipment used MUST be intrinsically safe.

The rest of this section is divided into sub-sections based upon the type of module, as follows.

6.1 Digital Input modules

MTL4501-SR, MTL4510, MTL4510B, MTL4511, MTL4513, MTL4514, MTL4516, MTL4516C, MTL4517

6.2 Digital Output modules

MTL4521, MTL4521L, MTL4523, MTL4523R, MTL4523L, MTL4524, MTL4524S, MTL4525, MTL4526

6.3 Pulse and Vibration modules

MTL4531, MTL4532, MTL4533

6.4 Analogue Input modules

MTL4541, MTL4541A, MTL4541AS, MTL4541B, MTL4541P, MTL4541S, MTL4544, MTL4544A, MTL4544AS, MTL4544B, MTL4544D, MTL4544S

6.5 Analogue Output modules

MTL4546, MTL4546C, MTL4546Y, MTL4549, MTL4549C, MTL4549Y

6.6 Fire and Smoke Interface modules

MTL4561

6.7 Temperature Input modules

MTL4575, MTL4576-RTD, MTL4576-THC

6.8 General modules

MTL4599, MTL4599N

6.9 PCS45/PCL45USB configurator for MTL temperature converters

Note: Any LED indicators provided on the modules will display in the following colours:

LED label	LED colour
PWR (power)	Green
STS (status)	Yellow
LFD (line fault)	Red
FLT (fault)	Red
OPx (o/p status)	Yellow

6.1 Digital Input modules

The Digital Input (DI) module range offers solid state or relay output switches in a safe area that respond to input switches located in a hazardous area. Single or multiple channel (2 or 4) options are available, as well as **Line-Fault Detection (LFD)**.

Modules with LFD can recognise open or short circuit conditions on the input wires going to the field sensors, and some DI modules have the facility to reverse the effect of the input on the output i.e. **phase reversal**.

These options are chosen with switches located on the edge of the module on the hazardous area terminal side. In some applications it may be easier to set these switches *before* fitting the module to the backplane.

Figure 6.1:
Switches
to set LFD and
phase reversal

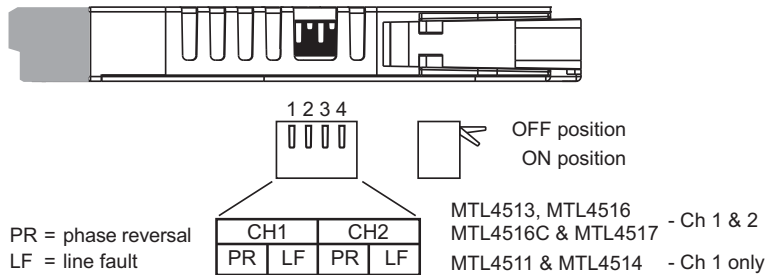

6.1.1 Phase reversal

Set the PR switch ON or OFF for the appropriate channel(s).

6.1.2 Line-Fault Detection (LFD)

Where fitted, set the LF switch ON or OFF for the appropriate channel(s). **Note:** LFD is permanently active on the MTL4501-SR.

For all DI modules with LFD **except for the MTL4501-SR**; when using the LFD facility with a contact input, resistors must be used. Fit 500Ω to 1kΩ (preferred value 680Ω) in series with the switch and 20kΩ to 25kΩ (preferred value 22kΩ) in parallel with the switch.

For modes of operation of the MTL4510 & MTL4510B that include LFD, resistors should be fitted as described above.

For MTL4501-SR use 1k4Ω in series and 10kΩ in parallel with switch contact inputs.

For hazardous-area inputs conforming to EN 60947-5-6:2001 (NAMUR), a line fault is judged by the following rules:

- ◆ Open circuit condition if hazardous-area current <50μA
- ◆ Line integrity (no open circuit) if hazardous-area current >250μA
- ◆ Short circuit condition if hazardous-area load <100Ω
- ◆ Line integrity (no short circuit) if hazardous-area load >360Ω

Note: the open circuit window (between 250μA and 50μA), and the short circuit window (between 100Ω and 360Ω), is not hysteresis. All MTL4500 Series modules, with inputs conforming to EN 60947-5-6:2001 (NAMUR), will switch between open and complete circuit conditions within these limits.

Under line fault conditions, the associated output will be de-energised and the LFD LED will be lit. For modules with separate LFD outputs, except for the MTL4501-SR, the LFD output will be **energised** to indicate the fault condition.

6.1.3 MTL4501-SR - Fail-safe Switch/Proximity detector interface

Single channel, fail-safe module with line-fault detection

The MTL4501-SR, enables a fail-safe switch/proximity detector located in the hazardous area to control an isolated fail-safe electronic output. It provides line-fault detection alarm contacts and is designed for use with approved fail-safe sensors in loops that require operation up to SIL3 according to the functional safety standard IEC 61508.

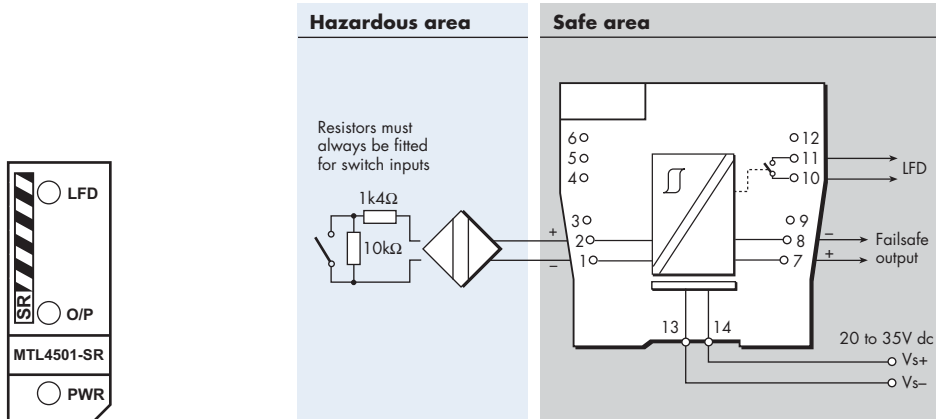

Figure 6.2:
Top label
for MTL4501-SR

Terminal	Function
1	Input -ve
2	Input +ve
7	Output +ve
8	Output -ve
10	LFD
11	LFD
13	Supply -ve
14	Supply +ve

Input / output characteristics

Input value in sensor circuits	Fail-safe output	Operation	LFD contacts
$2.9\text{mA} < I_s < 3.9\text{mA}$	ON	Normal	CLOSED
$I_s < 1.9\text{mA} \ \& \ I_s > 5.1\text{mA}$	OFF	Normal	CLOSED
$I_s < 50\mu\text{A}$	OFF	Broken line	OPEN
$R_s < 100\Omega$	OFF	Shorted line	OPEN

6.1.4 MTL4510 & MTL4510B - Switch/Proximity detector interface

4-channel, digital input and multifunction modules

These digital modules provide solid state output switches in a safe area that respond to switches (inputs) located in a hazardous area. The way they respond - their "mode" - can be configured using a bank of four DIL selector switches accessible through the side of the module - see Figure 6.4.

Model MTL4510 has an one output channel for each input channel and the user can reverse the output phase if necessary to suit the application. Model MTL4510B has more varied modes that can, for example, enable one input to affect multiple outputs or create latched outputs, etc.)

Note that series and parallel resistors are required for switch inputs with LFD - see Section 6.1.2 for recommended values.

Tables 6.1 and 6.2 show details of the modes available and the switch settings required to obtain them.

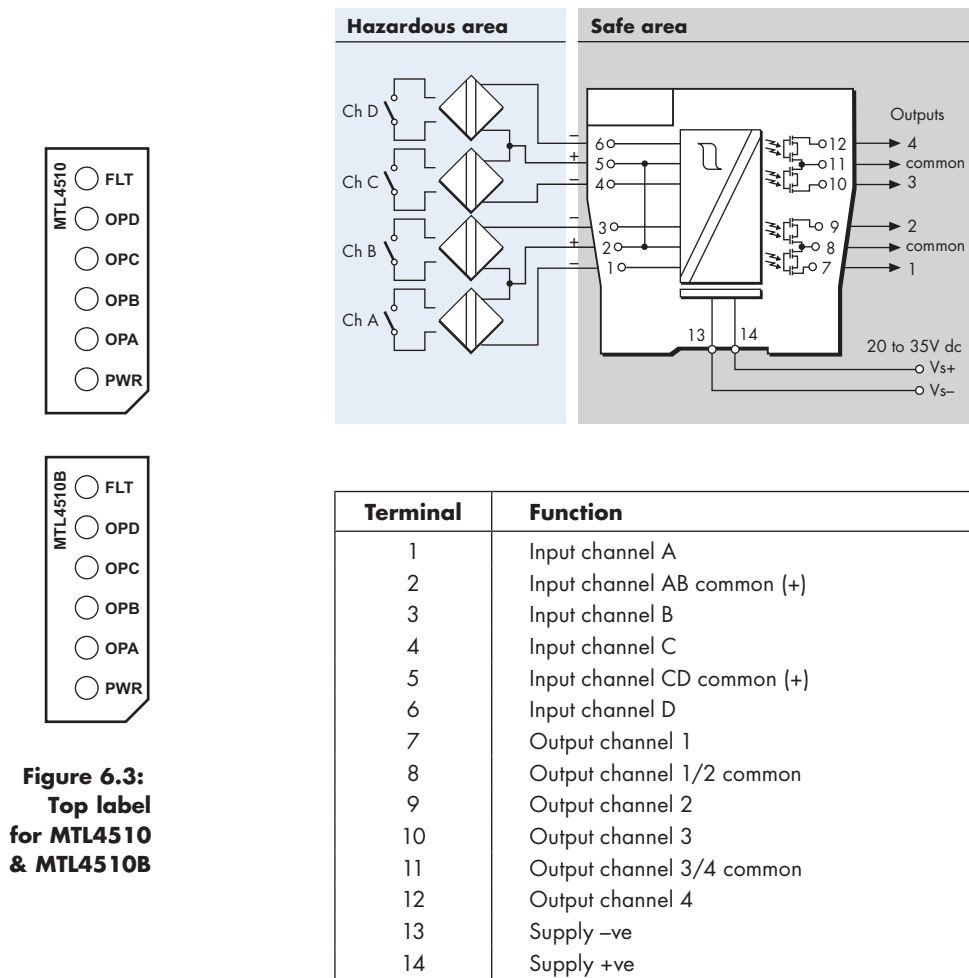
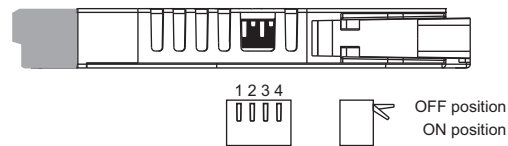

Figure 6.3:
Top label
for MTL4510
& MTL4510B

Figure 6.4:
DIL switches
for setting
MODE



For ease of access, it is recommended that switches are set to the required mode *before* installation.

Table 6.1 indicates whether the output follows the input, or the output is the reverse or antiphase of the input.

For example, in mode 0, o/p 1 = chA; so, if channel A switch is closed, then output 1 will also be closed or short circuit. However, in mode 1, o/p 1 = chA rev., so if channel A switch is closed, then output 1 will be the reverse, i.e. open-circuit.

Table 6.1 - MTL4510 mode options

Switch setting				MODE	o/p 1	o/p 2	o/p 3	o/p 4	i/p type
1	2	3	4						
OFF	OFF	OFF	OFF	0	chA	chB	chC	chD	switch
ON	OFF	OFF	OFF	1	chA rev.	chB	chC	chD	
OFF	ON	OFF	OFF	2	chA	chB rev.	chC	chD	
ON	ON	OFF	OFF	3	chA	chB	chC rev.	chD	
OFF	OFF	ON	OFF	4	chA	chB	chC	chD rev.	
ON	OFF	ON	OFF	5	chA rev.	chB	chC rev.	chD	
OFF	ON	ON	OFF	6	chA	chB rev.	chC	chD rev.	
ON	ON	ON	OFF	7	chA rev.	chB rev.	chC rev.	chD rev.	prox. detector + LFD
OFF	OFF	OFF	ON	8	chA	chB	chC	chD	
ON	OFF	OFF	ON	9	chA rev.	chB	chC	chD	
OFF	ON	OFF	ON	10	chA	chB rev.	chC	chD	
ON	ON	OFF	ON	11	chA	chB	chC rev.	chD	
OFF	OFF	ON	ON	12	chA	chB	chC	chD rev.	
ON	OFF	ON	ON	13	chA rev.	chB	chC rev.	chD	
OFF	ON	ON	ON	14	chA	chB rev.	chC	chD rev.	
ON	ON	ON	ON	15	chA rev.	chB rev.	chC rev.	chD rev.	

Table 6.2 shows the **MTL4510B** modes. The logic tables and timing diagrams on the following pages provide more detailed information on these modes.

Table 6.2 - MTL4510B mode options

Switch settings				MODE	Function	Equivalent
1	2	3	4			
OFF	OFF	OFF	OFF	0	4-ch switch input (see MTL4510 mode 0)	MTL4510
ON	OFF	OFF	OFF	1	2-ch each channel one input, two outputs	MTL4016
OFF	ON	OFF	OFF	2	Same as mode 1 with repeat output phase reversed	MTL4016
ON	ON	OFF	OFF	3	2-ch, 2-pole changeover output	
OFF	OFF	ON	OFF	4	1-ch with line fault output	MTL4014
ON	OFF	ON	OFF	5	As mode 4 with changeover outputs	
OFF	ON	ON	OFF	6	1-ch with start-stop latch	MTL2210B
ON	ON	ON	OFF	7	4-ch switch input, see MTL4510 mode 7	MTL4510
OFF	OFF	OFF	ON	8	4-ch switch input, see MTL4510 mode 8	MTL4510
ON	OFF	OFF	ON	9	2-ch with line fault output	MTL4017
OFF	ON	OFF	ON	10	As mode 9 with LFD changeover	
ON	ON	OFF	ON	11	As mode 10 with channel phase reversed	
OFF	OFF	ON	ON	12	3-ch with normally-open LFD output	
ON	OFF	ON	ON	13	3-ch with normally-closed LFD output	
OFF	ON	ON	ON	14	2-ch monostable, pulse stretcher	
ON	ON	ON	ON	15	4-ch switch input, see MTL4510 mode 15	MTL4510

MTL4510 & MTL4510B diagnostics

If an internal fault is detected, all outputs and channel LEDs will turn off and the red Fault LED will turn ON.

MTL4510B modes

The following logic and timing diagrams are provided to assist the user in understanding the behaviour of the MTL4510B module when a specific **mode** is chosen.

The open switch (—/—) and closed switch (—o—) symbols are used to represent both the input conditions of Ch A, Ch B, Ch C or Ch D and then the output conditions of o/p 1, 2, 3 or 4. Note that in certain modes a Line Fault can cause an override of the output.

Mode 1

i/p - Ch A		i/p - Ch C	
o/p 1	—/—	—o—	—o—
o/p 2	—	—	—
o/p 3	—/—	—o—	—o—
o/p 4	—	—	—

How to use these mode tables - examples

The logic tables (right) for Mode 1 represent Ch A controlling outputs 1 & 3, while Ch C controls outputs 2 & 4.

Output 1 & 3 are shown following input Ch A (open or closed) while Outputs 2 & 4 follow input Ch C.

Mode 2 however shows o/p 3 and 4 being in antiphase to their inputs.

Mode 2

i/p - Ch A		i/p - Ch C	
o/p 1	—/—	—o—	—o—
o/p 2	—	—	—
o/p 3	—o—	—/—	—o—
o/p 4	—	—	—

Mode 3

i/p - Ch A		i/p - Ch C	
o/p 1	—/—	—o—	—o—
o/p 2	—o—	—/—	—o—
o/p 3	—	—	—
o/p 4	—o—	—/—	—o—

Mode 4

i/p - Ch A			
No fault	Line fault	No fault	Line fault
o/p 1	—/—	—o—	—o—
o/p 3	—o—	—/—	—o—

Mode 5

i/p - Ch A			
No fault	Line fault	No fault	Line fault
o/p 1	—/—	—o—	—o—
o/p 2	—o—	—/—	—o—
LFD o/p 3	—o—	—/—	—o—
LFD o/p 4	—/—	—o—	—o—

Mode 6

i/p Ch C	Non-latching —/—		OR	Latching —o—		
i/p Ch B	Enable —o—			i/p Ch A	Start —/—	Reset —o—
i/p Ch A	—/—	—o—		i/p Ch B	No effect —/—	Stop —o—
o/p 1	—o—	—o—		o/p 1	—o—	—o—
o/p 2	—o—	—o—		o/p 2	—o—	—o—
o/p 3	—o—	—o—		o/p 3	—o—	—o—
o/p 4	—o—	—o—		o/p 4	—o—	—o—

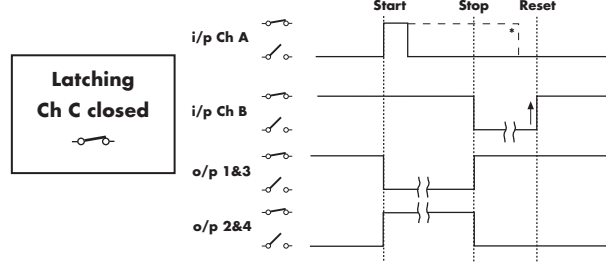
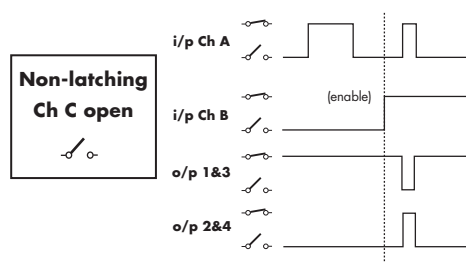

* i/p Ch A can be open or closed when i/p Ch B opens to stop latch

MTL4510B modes - continued

Mode 9

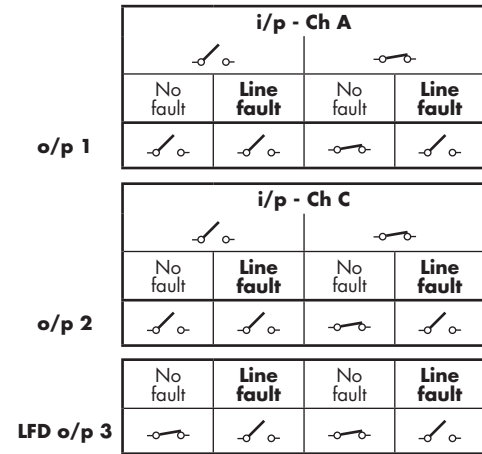

Mode 10

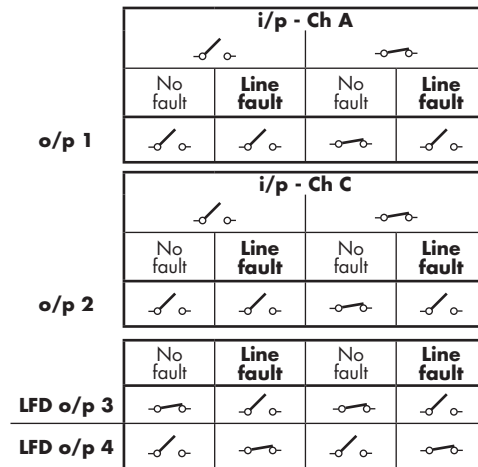

Mode 11

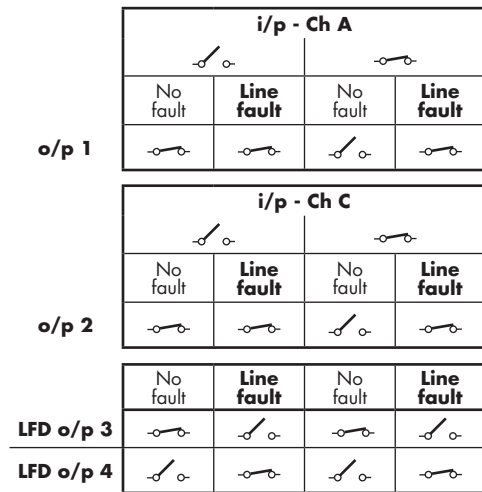

Mode 12

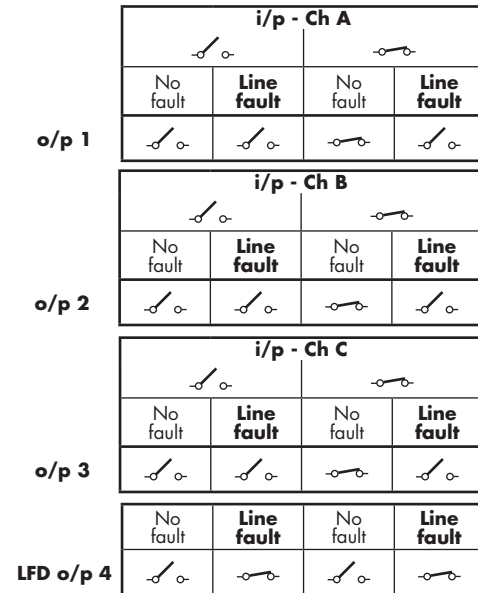

Mode 13

As mode 12 but with LFD o/p 4 reversed

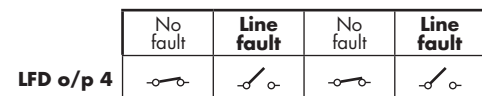

Mode 14

This mode provides a two channel pulse stretcher for inputs A and C. Outputs 1 and 2 respond to Ch A, while 3 and 4 respond to Ch C. Input B (or D) being open or closed affects the input transition and the output polarity as shown in the timing diagrams below.

Input Ch B (or D) closed

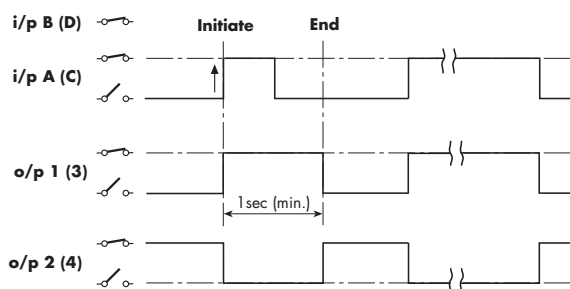

Input Ch B (or D) open

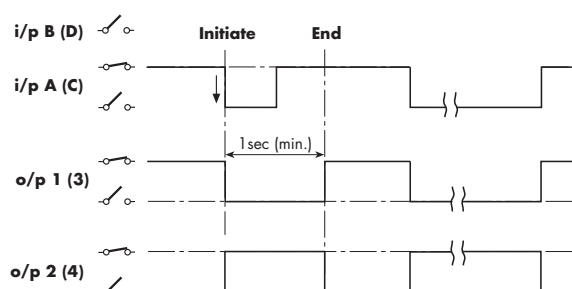

6.1.5 MTL4511 - Switch/Proximity detector interface

Single channel, with line-fault detection

The MTL4511 contains a changeover relay, which enables a safe-area load to be controlled by a switch or proximity detector located in a hazardous-area. When selected, the line-fault detect (LFD) facility detects open or short circuit conditions in the field wiring and also indicates this on the top of the module. **Line-Fault Detect** and **Phase Reversal** for the channel are selected by DIL switches on the side of the module and output is provided by the changeover relay contacts.

See page 12 for LFD and PR switch details. **Channel 1 only** switch settings apply.

For switch sensor inputs, with LFD selected, make sure resistors (22kΩ and 680Ω) are fitted.

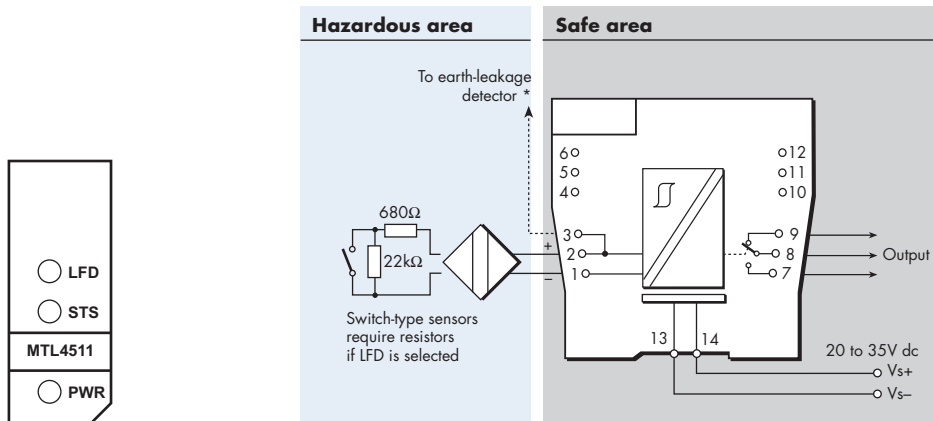

Figure 6.5:
Top label
for MTL4511

Terminal	Function
1	Input -ve
2	Input +ve
3	To earth leakage detector*
7	Output normally-open contact
8	Common
9	Output normally-closed contact
13	Supply -ve
14	Supply +ve

* Signal plug HAZ1-3 is required for access to this function

6.1.6 MTL4513 - Switch/Proximity detector interface

Two-channel, with line-fault detection and phase reversal

The MTL4513 enables two solid-state outputs in the safe area to be controlled by two switches or proximity detectors located in the hazardous area. The Ch1/Ch2 output transistors share a common terminal and can switch +ve or -ve polarity signals. **Line-Fault Detect** and **Phase Reversal** for the channel are selected by DIL switches on the side of the module. LFD indication is provided on the top of the module.

See page 12 for LFD and PR switch details. **Channel 1 & 2** switch settings apply.

For switch sensor inputs, with LFD selected, make sure resistors (22kΩ and 680Ω) are fitted.

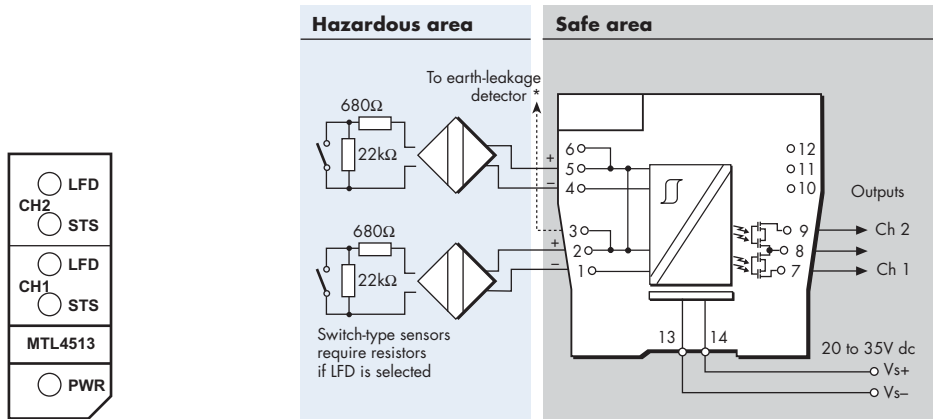

Figure 6.6:
Top label
for MTL4513

Terminal	Function
1	Input -ve (Ch 1)
2	Input +ve (Ch 1)
3	To earth leakage detector*
4	Input -ve (Ch 2)
5	Input +ve (Ch 2)
6	To earth leakage detector*
7	Output (Ch 1)
8	Output (Ch 1/Ch 2)
9	Output (Ch 2)
13	Supply -ve
14	Supply +ve

* Signal plug HAZ1-3 is required for access to this function

6.1.7 MTL4514 - Switch/Proximity detector interface

Single channel, with line-fault detection and phase reversal

The MTL4514 enables a safe-area load to be controlled, through a relay, by a proximity detector or switch located in a hazardous area. Line faults are signalled through a separate relay and indicated on the top of the module. **Line-Fault Detect** and **Phase Reversal** for the channel are selected by DIL switches on the side of the module and output is provided by the changeover relay contacts.

See page 12 for LFD and PR switch details. **Channel 1 only** switch settings apply.

For switch sensor inputs, with LFD selected, make sure resistors (22kΩ and 680Ω) are fitted.

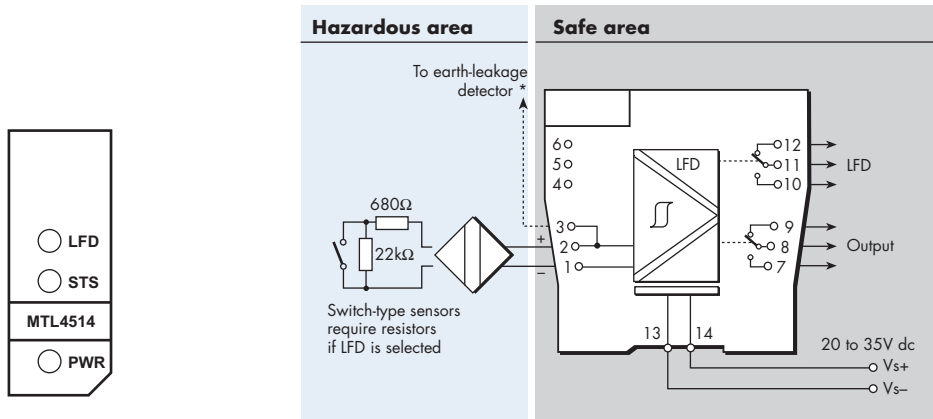

Figure 6.7:
Top label
for MTL4514

Terminal	Function
1	Input -ve
2	Input +ve
3	To earth leakage detector*
7	Normally-open contact (output)
8	Common (output)
9	Normally-closed contact (output)
10	Normally-open contact (LFD)
11	Common (LFD)
12	Normally-closed contact (LFD)
13	Supply -ve
14	Supply +ve

* Signal plug HAZ1-3 is required for access to this function

6.1.8 MTL4516 - Switch/Proximity detector interface

Two channel, with line-fault detection and phase reversal - normally-open contacts

The MTL4516 contains two normally-open contact relays, which enable two safe-area loads to be controlled by switches or proximity detectors located in a hazardous-area. When selected, the line-fault detect (LFD) facility detects open or short circuit conditions in the field wiring and also indicates this on the top of the module. **Line-Fault Detect** and **Phase Reversal** for the channel are selected by DIL switches on the side of the module and output is provided by the changeover relay contacts.

See page 12 for LFD and PR switch details. **Channel 1 & 2** switch settings apply.

For switch sensor inputs, with LFD selected, make sure resistors (22kΩ and 680Ω) are fitted.

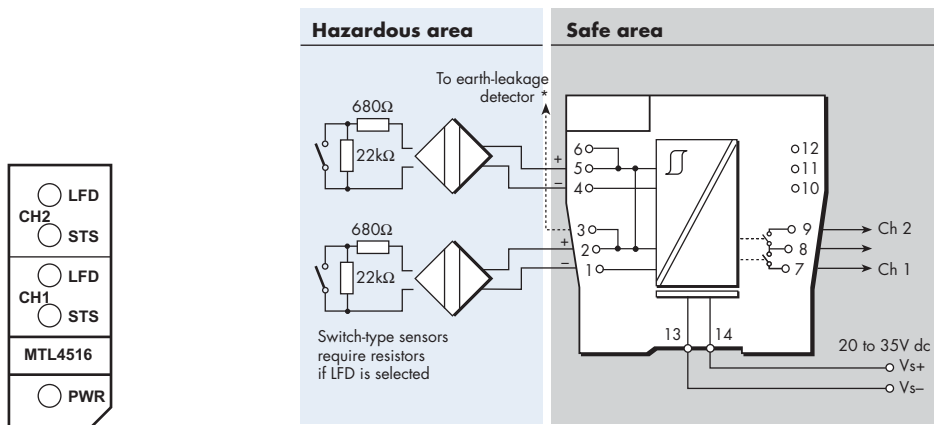

Figure 6.8:
Top label
for MTL4516

Terminal	Function
1	Input -ve (Ch 1)
2	Input +ve (Ch 1)
3	To earth leakage detector*
4	Input -ve (Ch 2)
5	Input +ve (Ch 2)
6	To earth leakage detector*
7	Output (Ch 1)
8	Common (Ch 1/Ch 2)
9	Output (Ch 2)
13	Supply -ve
14	Supply +ve

* Signal plug HAZ1-3 is required for access to this function

6.1.9 MTL4516C - Switch/Proximity detector interface

Two channel, with line-fault detection and phase reversal - changeover contacts

The MTL4516C contains two changeover relays, which enable two safe-area loads to be controlled by switches or proximity detectors located in a hazardous-area. When selected, the line-fault detect (LFD) facility detects open or short circuit conditions in the field wiring and also indicates this on the top of the module. **Line-Fault Detect** and **Phase Reversal** for the channel are selected by DIL switches on the side of the module and output is provided by the changeover relay contacts.

See page 12 for LFD and PR switch details. **Channel 1 & 2** switch settings apply..

For switch sensor inputs, with LFD selected, make sure resistors (22kΩ and 680Ω) are fitted.

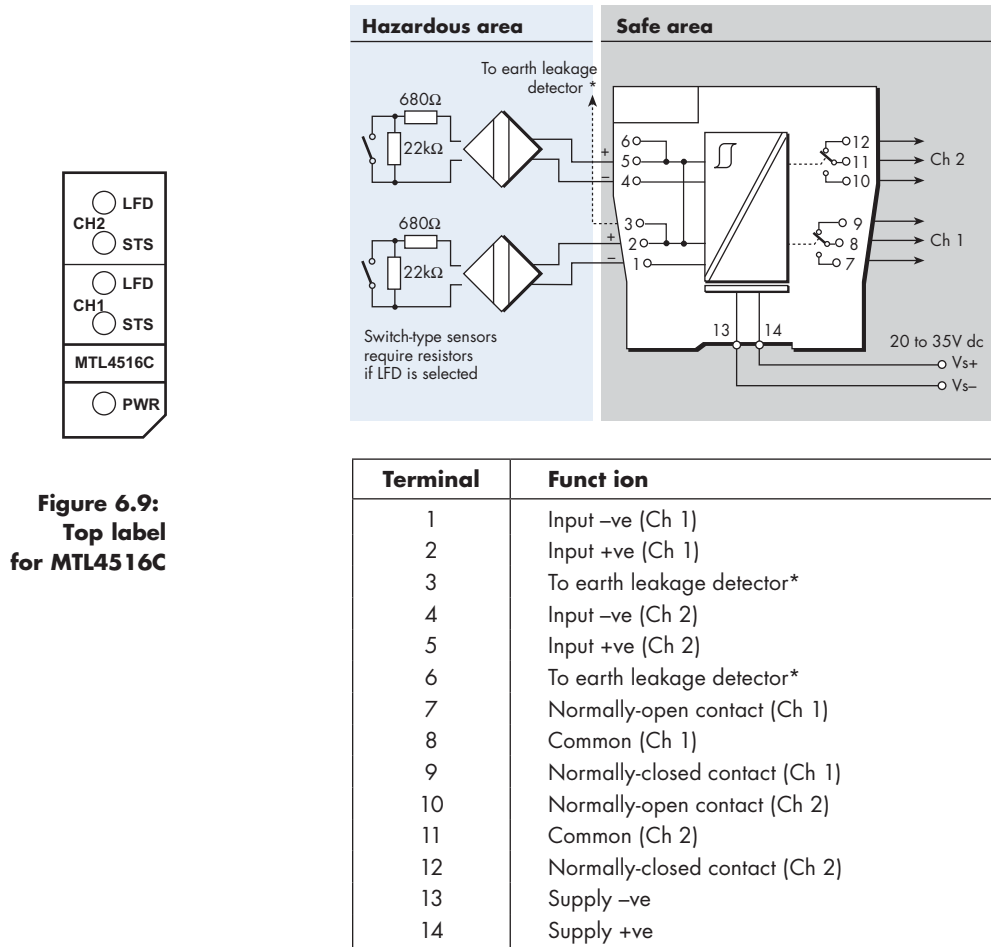

Figure 6.9:
Top label
for MTL4516C

* Signal plug HAZ1-3 is required for access to this function

6.1.10 MTL4517 - Switch/Proximity detector interface

Two channel, with line-fault detection and phase reversal

The MTL4517 enables two safe-area loads to be controlled, through a relay, by switches or proximity detectors located in a hazardous-area. When selected, the line-fault detect (LFD) is signalled through a separate relay and indicated on the top of the module. **Line-Fault Detect** and **Phase Reversal** for the channel are selected by DIL switches on the side of the module and output is provided by the relay contacts.

See page 12 for LFD and PR switch details. **Channel 1 & 2** switch settings apply.

For switch sensor inputs, with LFD selected, make sure resistors (22kΩ and 680Ω) are fitted.

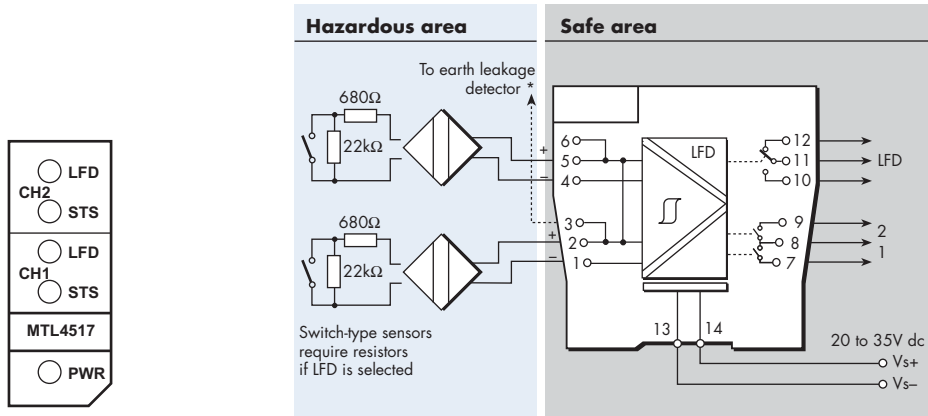

Figure 6.10:
Top label
for MTL4517

Terminal	Function
1	Input -ve (Ch 1)
2	Input +ve (Ch 1)
3	To earth leakage detector*
4	Input -ve (Ch 2)
5	Input +ve (Ch 2)
6	To earth leakage detector*
7	Output (Ch 1)
8	Common (Ch 1/Ch 2)
9	Output (Ch 1)
10	Normally-open contact (LFD)
11	Common (LFD)
12	Normally-closed contact (LFD)
13	Supply -ve
14	Supply +ve

* Signal plug HAZ1-3 is required for access to this function

6.2 Digital Output modules

The single channel Digital Output (DO) module range enables on/off devices in a hazardous area to be controlled from the safe area. Some units are loop powered while others enable solid-state switching by providing independent power supplies.

6.2.1 MTL4521/MTL4521L - Solenoid Alarm driver

Single channel, loop powered, IIC

The MTL4521 and MTL4521L are loop-powered modules that enable a device located in the hazardous area (IIC gas group) to be controlled from the safe area. They can both drive up to 48mA into a certified intrinsically safe low-power load, as well as non-energy-storing simple apparatus such as an LED. The only difference is that the MTL4521L has a lower current safety description i.e. 108mA instead of 147mA.

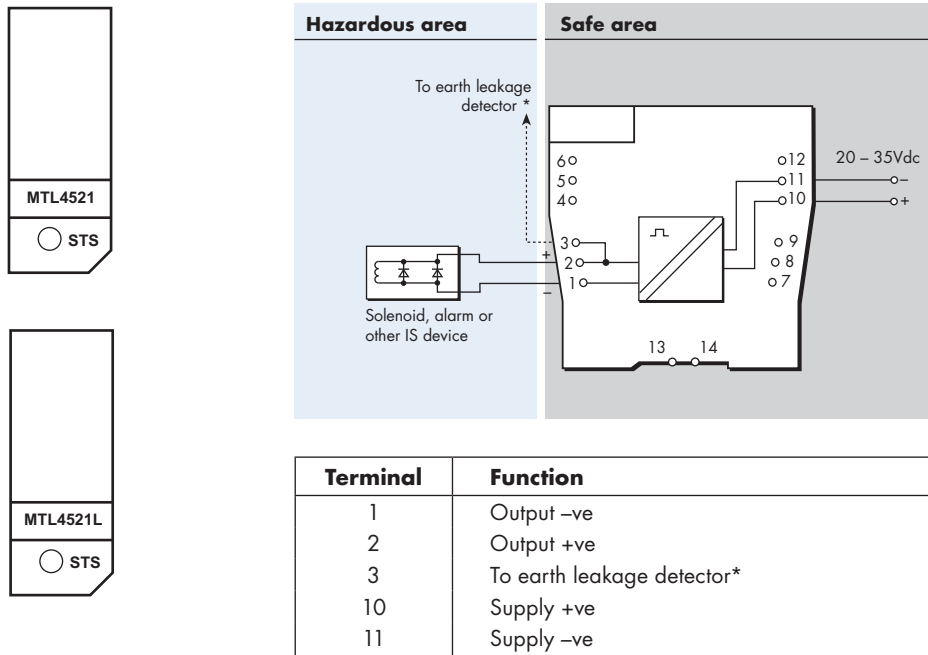

Figure 6.11:
Top label
for MTL4521
and MTL4521L

* Signal plug HAZ1-3 is required for access to this function

6.2.2 MTL4523/MTL4523R - Solenoid Alarm driver

Single channel, with line-fault detection, IIC

With the MTL4523 interface, an on/off device in a hazardous area can be controlled by a voltage signal in the safe area. It is suitable for driving loads such as solenoids. Line-Fault Detection (LFD), which operates irrespective of the output state, is signalled by a safe-area solid-state switch which de-energises MTL4523, or energises an MTL4523R, if a field line is open or short-circuited. Earth fault detection can be provided by connecting an MTL4220 earth leakage detector to terminal 3.

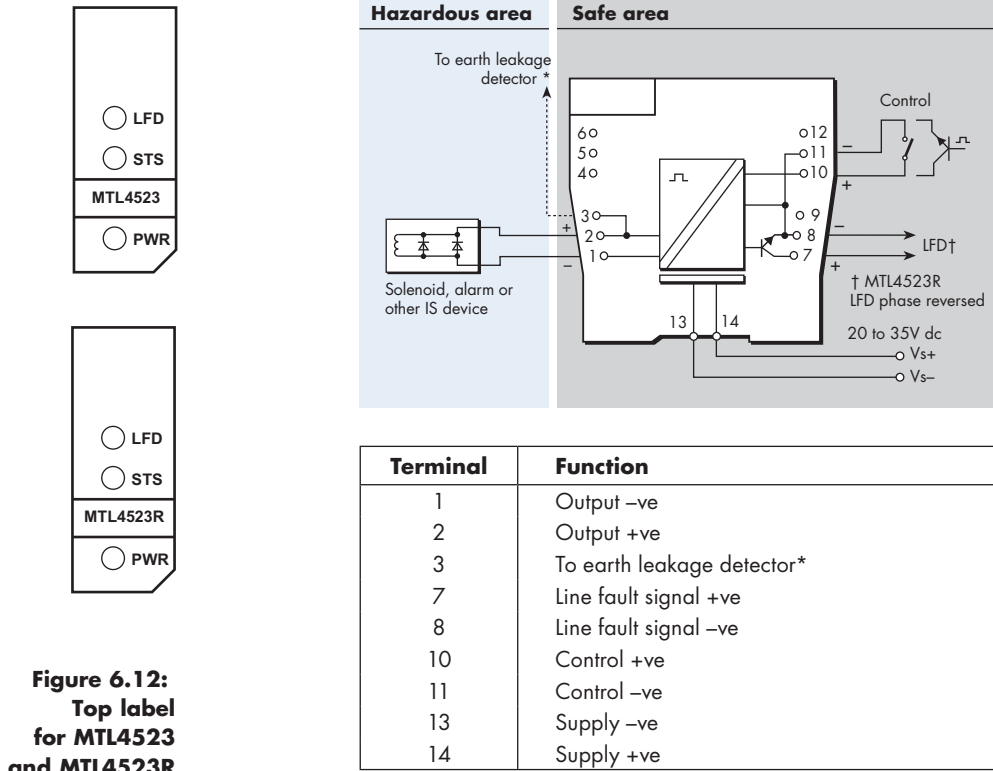

Figure 6.12:
Top label
for MTL4523
and MTL4523R

* Signal plug HAZ1-3 is required for access to this function

6.2.3 MTL4523L - Solenoid Alarm driver

Single channel, line powered with line-fault detection, IIC

With the MTL4523 interface, an on/off device in a hazardous area can be controlled by a voltage signal in the safe area. It is suitable for driving loads such as solenoids. Line-Fault Detection (LFD), which operates irrespective of the output state, is signalled by a safe-area solid-state switch which energises if a field line is open or short-circuited. Earth fault detection can be provided by connecting an MTL4220 earth leakage detector to terminal 3.

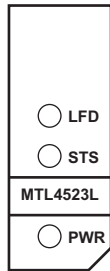
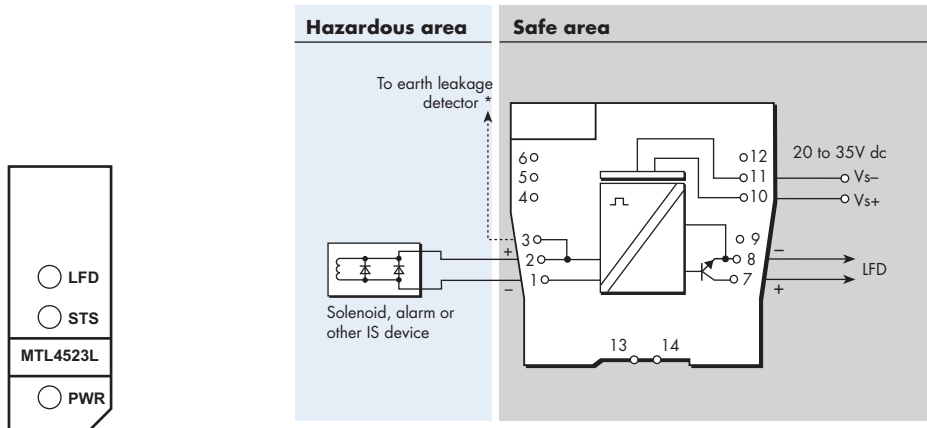

Figure 6.13:
Top label
for MTL4523L

Terminal	Function
1	Output -ve
2	Output +ve
3	To earth leakage detector*
7	Line fault signal +ve
8	Line fault signal -ve
10	Supply +ve
11	Supply -ve

* Signal plug HAZ1-3 is required for access to this function

6.2.4 MTL4524 - Solenoid Alarm driver

Single channel, switch operated with override, IIC

The MTL4524 enables an on/off device in a hazardous area to be controlled by a volt-free contact or logic signal in the safe area. It can drive loads such as solenoids, alarms, LEDs and other low power devices that are certified as intrinsically safe or are classified as non-energy-storing simple apparatus. By connecting a second safe-area switch or logic signal, the output can be disabled to permit, for example, a safety system to override a control signal.

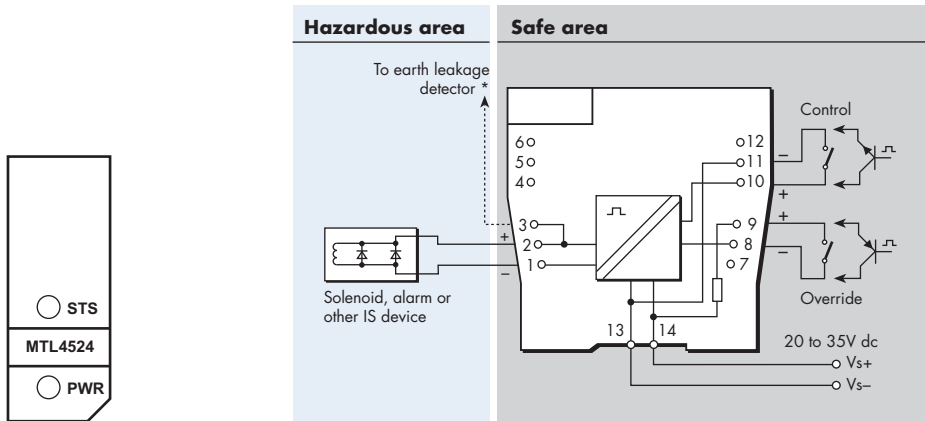

Figure 6.14:
Top label
for MTL4524

Terminal	Function
1	Output -ve
2	Output +ve
3	To earth leakage detector*
8	Override -ve
9	Override +ve
10	Control +ve
11	Control -ve
13	Supply -ve
14	Supply +ve

* Signal plug HAZ1-3 is required for access to this function

6.2.5 MTL4524S - Solenoid Alarm driver

Single channel, switch operated with 24V override, IIC

The MTL4524 enables an on/off device in a hazardous area to be controlled by a volt-free contact or a floating logic signal in the safe area. It can drive loads such as solenoids, alarms, LEDs and other low power devices that are certified as intrinsically safe or are classified as non-energy-storing simple apparatus. By connecting a second safe-area switch or logic signal, the output can be disabled to permit, for example, a safety system to override a control signal.

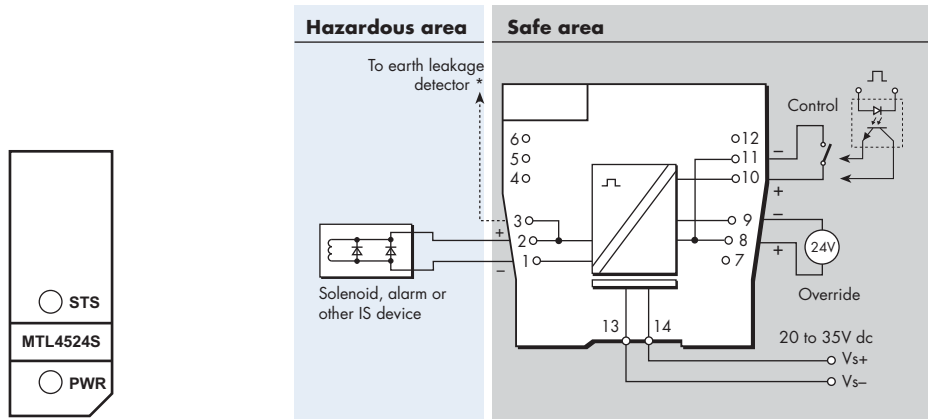

Figure 6.15:
Top label
for MTL4524S

Terminal	Function
1	Output -ve
2	Output +ve
3	To earth leakage detector*
8	Override +ve
9	Override -ve
10	Control +ve
11	Control -ve
13	Supply -ve
14	Supply +ve

* Signal plug HAZ1-3 is required for access to this function

6.2.6 MTL4525 - Solenoid Alarm driver

Single channel, switch operated with override, IIC

The MTL4525 enables an on/off device in a hazardous area to be controlled by a volt-free contact or logic signal in the safe area. It can drive loads such as solenoids, alarms, LEDs and other low power devices that are certified as intrinsically safe or are classified as non-energy-storing simple apparatus. By connecting a second safe-area switch or logic signal, the output can be disabled to permit, for example, a safety system to override a control signal.

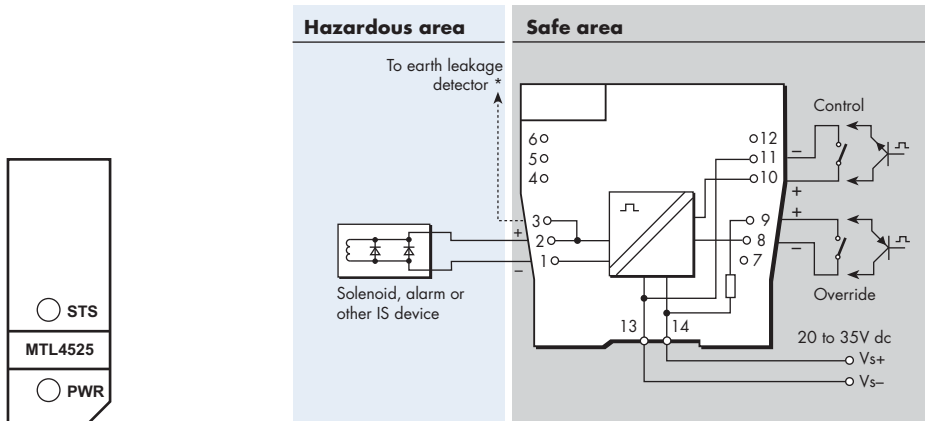

Figure 6.16:
Top label
for MTL4525

Terminal	Function
1	Output -ve
2	Output +ve
3	To earth leakage detector*
8	Override -ve
9	Override +ve
10	Control +ve
11	Control -ve
13	Supply -ve
14	Supply +ve

* Signal plug HAZ1-3 is required for access to this function

6.2.7 MTL4526 - Switch operated relay

Two channel, IS output

The MTL4526 enables two separate IS circuits in a hazardous area to be relay-contact controlled by two on-off switches or logic signals in a safe area. Applications include the calibration of strain-gauge bridges; changing the polarity (and thereby the tone) of an IS sounder; the testing of IS fire alarms; and the transfer of safe-area signals into an annunciator with IS input terminals not segregated from each other. The output-relay contacts are certified as non-energy-storing apparatus, and can be connected to any IS circuit without further certification, provided that separate IS circuits are such that they would remain safe if connected together.

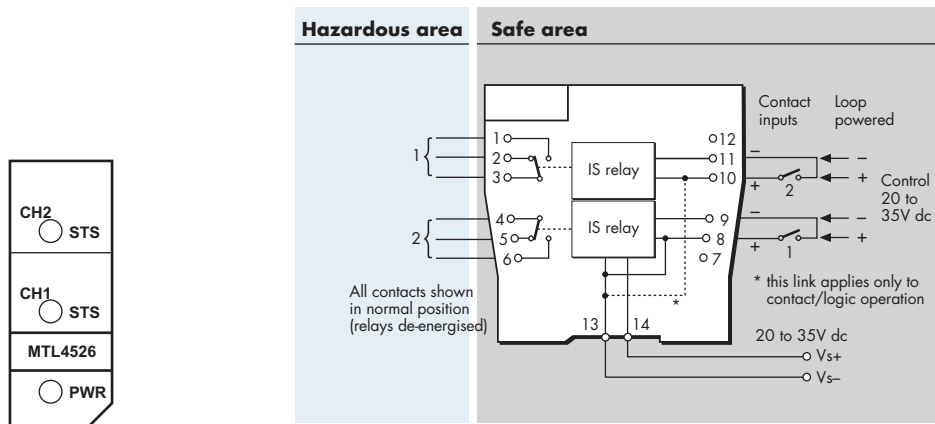

Figure 6.17:
Top label
for MTL4526

Terminal	Function
1	IS relay output 1 (normally open)
2	IS relay output 1 (normally closed)
3	IS relay output 1 (common)
4	IS relay output 2 (common)
5	IS relay output 2 (normally closed)
6	IS relay output 2 (normally open)
8	Relay 1 control +ve
9	Relay 1 control -ve
10	Relay 2 control +ve
11	Relay 2 control -ve
13	Supply -ve
14	Supply +ve

Table 6.3
Switch settings
for modes

Mode	Function	SW1	SW2	SW3	SW4
Contact/Logic	2 ch	Off	On	On	On
Input	1in2out	On	On	On	On
Loop Powered	2 ch	Off	Off	Off	Off

6.3 Pulse and Vibration modules

Single and dual channel modules are available to transfer vibration probe signals from a hazardous area to a safe one. Similarly, pulses from a switch, proximity detector, current pulse transmitter or voltage pulse transmitter, located in the hazardous area, can be safely transferred to the safe area.

6.3.1 MTL4531 - Vibration Transducer Interface

Single channel

The MTL4531 repeats a signal from a vibration sensor in a hazardous area, providing an output for a monitoring system in the safe area. The interface is compatible with 3-wire, eddy-current probes and accelerometers or 2-wire current sensors, and selection of the mode is made with a switch located on the side of the module.

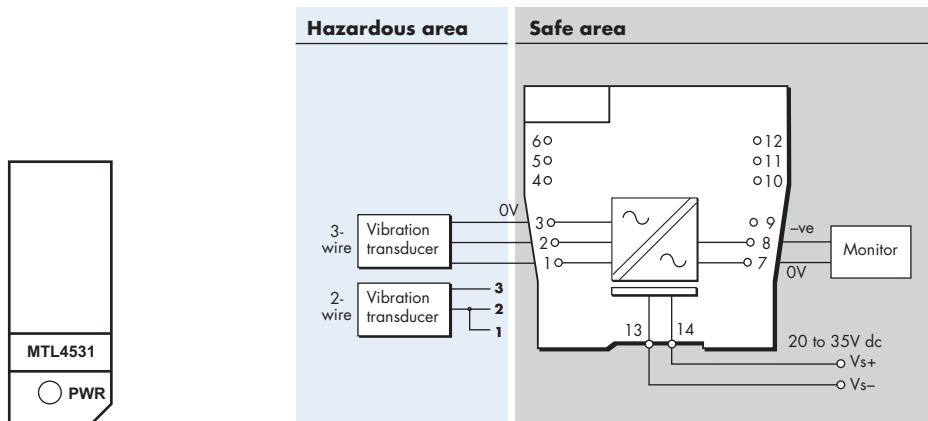
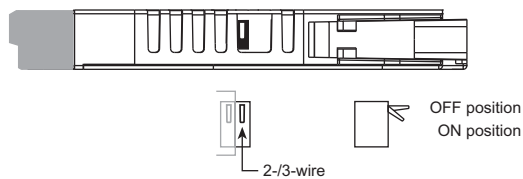

Figure 6.18:
Top label
for MTL4531

Terminal	Function
1	Transducer power V-
2	Signal
3	Common
7	Signal output 0V
8	Signal output -ve
13	Supply -ve
14	Supply +ve

2-/3-wire transducer setting switch



Mode	SW
2-wire (3.3mA)	OFF
3-wire (20mA)	ON

6.3.2 MTL4532 - Pulse Isolator

Pulse & 4/20mA current outputs

The MTL4532 isolates pulses from a switch, proximity detector, current pulse transmitter or voltage pulse transmitter located in a hazardous area. It is ideal for applications involving high pulse rates and fast response times, by repeating the pulses into the safe area. With configuration, an analogue output proportional to frequency is available, together with a relay output, which may act as an alarm. Configuration requires a personal computer, a PCL45USB interface and PCS45 software. See Section 6.9 on page 50 for details of the configurator.

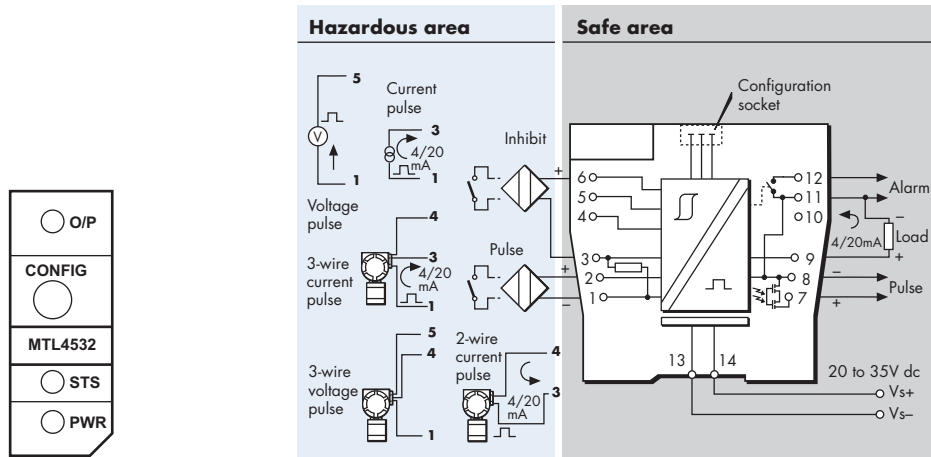
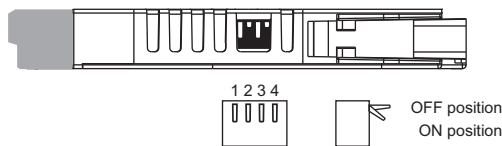

Figure 6.19:
Top label
for MTL4532

Terminal	Function
1	Common input -ve
2	Switch/proximity input +ve
3	Current pulse input +ve
4	Transmitter supply +ve
5	Voltage pulse input +ve
6	Inhibit input +ve
7	Pulse output +ve
8	Pulse/Current output -ve
9	Current output +ve
11	Alarm/Current output -ve
12	Alarm
13	Supply -ve
14	Supply +ve

Switches located on the edge of the module define the mode of operation.



SW1	SW2	SW3	SW4
Vsp	Vsp	LFD	Mode

Vsp	SW1	SW2
3V	ON	ON
6V	ON	OFF
12V	OFF	OFF

LFD	SW3
OFF	OFF
ON	ON

Legacy mode - SW4 - OFF

In this mode, only pulse output (terminals 7/8) operation is available, and the module emulates the earlier MTL5032 pulse isolator, with input switching point voltage (Vsp) thresholds defined by Switches 1 & 2, and LFD operation set with Switch 3. When Switch 3 is ON, the Alarm output (terminals 11 & 12) is also active.

Micro-controller (μ C) mode - SW4 - ON

In μ C mode, analogue, alarm and pulse outputs are available but the module *must* be software configured to define its operating mode. In this mode, software controls the LFD function and Switch 3 has no effect. Switches 1 & 2 continue to define the switching point threshold (Vsp).

Inhibit mode

The Inhibit input is provided to inhibit alarm output operation. This facility is useful, for example, during power-up, when pulse rates are below the alarm threshold. When normal operational values are established the inhibit can be disabled. Such a facility is sometimes referred to as a start-up delay. Inhibit is enabled by connecting a switch or proximity detector between terminals 6 and 3. If switch contacts are used for this input, then series and parallel resistors must be fitted - see Section 6.1.2 for recommended values.

LED indicators

Use the following LED information to understand the module status.

LED	Description
PWR Power (green)	ON - Power OK OFF - No power or insufficient voltage
O/P Output (yellow)	The LED will follow the pulse output state. If the output is pulsing then the LED brightness will pulse. If the pulsing is rapid or very short, the LED may dim if it is unable to respond to such changes. If the output is high, the LED will be ON.
STS Status (red - flashing)	In legacy mode a line fault will cause the LED to turn ON. In μ C mode, the LED is programmable to display a line fault or an Alarm trip operation. In the event, it will also indicate a μ C fault condition.

Switch Pulse Input operation

If switch contacts are used for this Pulse Input (terminals 1 & 2), then series and parallel resistors must be fitted - see Section 6.1.2 for recommended values.

6.3.3 MTL4533 - Vibration Transducer Interface

Two channel

The MTL4533 repeats a signal from a vibration sensor in a hazardous area, providing an output for a monitoring system in the safe area. The interface is compatible with 3-wire eddy-current probes and accelerometers or 2-wire current sensors, and selection of the mode for each channel is made with the switches on the side of the module.

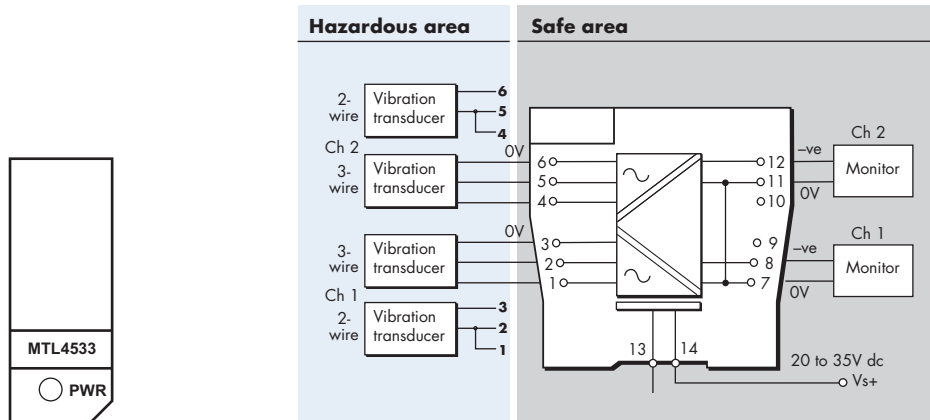
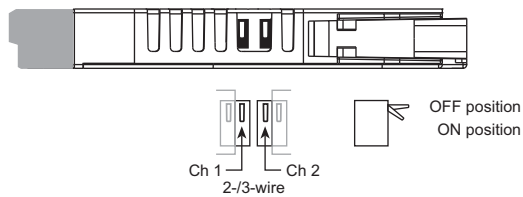

Figure 6.20:
Top label
for MTL4533

Terminal	Function
1	Ch 1 Transducer power V-
2	Ch 1 Signal
3	Ch 1 Common
4	Ch 2 Transducer power V-
5	Ch 2 Signal
6	Ch 2 Common
7	Ch 1 Signal output 0V
8	Ch 1 Signal output -ve
11	Ch 2 Signal output 0V
12	Ch 2 Signal output -ve
13	Supply -ve
14	Supply +ve

2-/3-wire transducer setting switches



Mode	SW
2-wire (3.3mA)	OFF
3-wire (20mA)	ON

6.4 Analogue Input modules

The analogue input (AI) modules support 2-wire or 3-wire 4/20mA or HART transmitters located in a hazardous area; repeating the current in other circuits to drive safe-area loads.

6.4.1 MTL4541/MTL4541S - Repeater Power Supply

Single channel, 4/20mA, HART® for 2- or 3-wire transmitters

The MTL4541 provides a fully-floating dc supply for energising a conventional 2- or 3-wire 4/20mA transmitter which is located in a hazardous area, and repeats the current in another floating circuit to drive a safe-area load. For HART 2-wire transmitters, the unit allows bi-directional communications signals superimposed on the 4/20mA loop current.

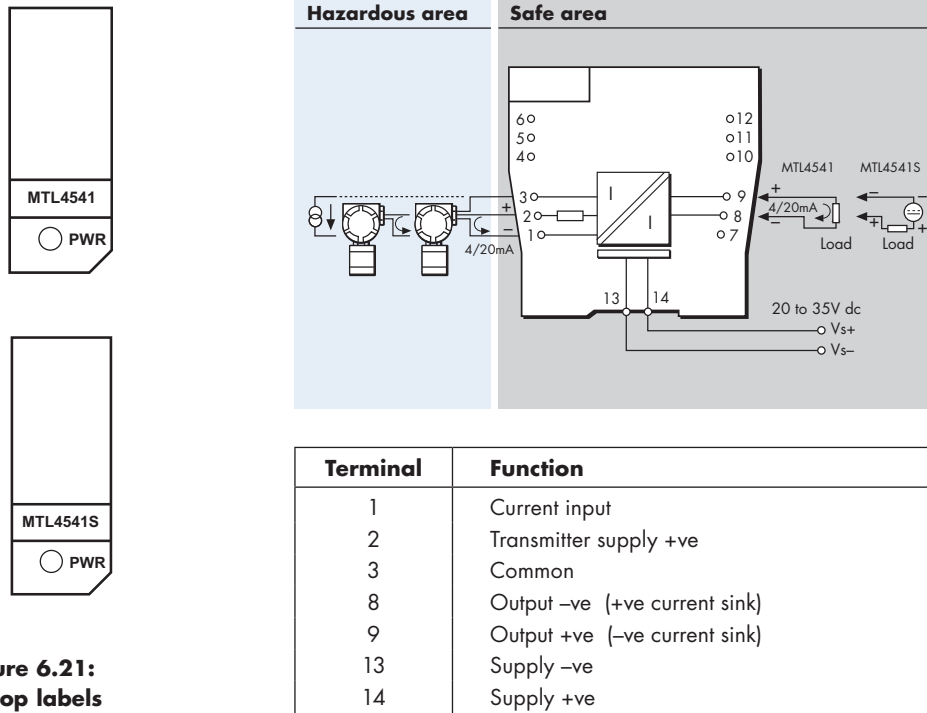
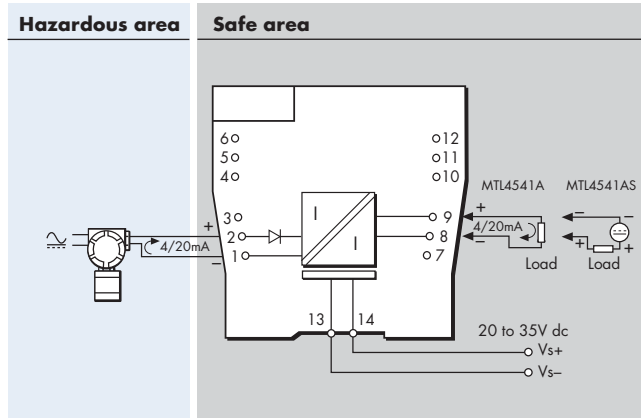
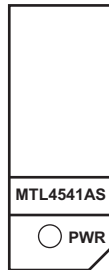
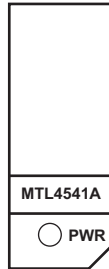

Figure 6.21:
Top labels
for MTL4541/
& MTL4541S

6.4.2 MTL4541A/MTL4541AS - Repeater Power Supply

Single channel, 4/20mA, passive input for HART® transmitters

The MTL4541A provides an input for separately powered 4/20mA transmitters and also allows bi-directional transmission of HART communication signals superimposed on the 4/20mA loop current. Alternatively, the MTL4541AS acts as a current sink for a safe-area connection rather than driving a current into the load.



Terminal	Function
1	Input -ve
2	Input +ve
8	Output -ve (+ve current sink)
9	Output +ve (-ve current sink)
13	Supply -ve
14	Supply +ve

Figure 6.22:
Top labels
for MTL4541A
& MTL4541AS

6.4.3 MTL4541B/MTL4541P - Repeater Power Supply

Single channel, 4/20mA, HART® for 2- or 3-wire transmitters

The MTL4541B and MTL4541P modules provide a fully-floating dc supply for energising a conventional 2- or 3-wire 4/20mA transmitter located in a hazardous area, and repeat the current in another circuit to drive a safe-area load. For HART 2-wire transmitters, the units allow bi-directional communications signals superimposed on the 4/20mA loop current.

The MTL4541P is a higher power version of the MTL4541B, usable for all gas groups provided that the field equipment is suitably certified.

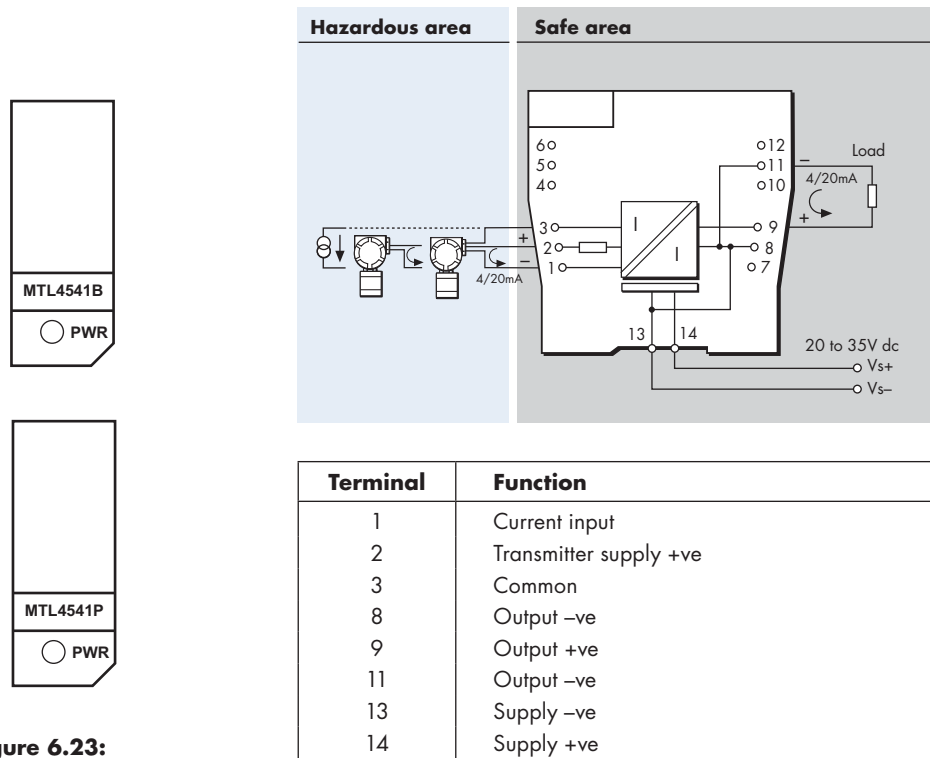

Figure 6.23:
Top labels
for MTL4541B
& MTL4541P

Note: Safe area outputs are referenced to PSU -ve

6.4.4 MTL4544/MTL4544S - Repeater Power Supply

Two channel, 4/20mA, HART® for 2- or 3-wire transmitters

The MTL4544 provides fully-floating dc supplies for energising two conventional 2-wire or 3-wire 4/20mA or HART transmitters located in a hazardous area, and repeats the current in other circuits to drive two safe-area loads. For HART transmitters, the unit allows bi-directional transmission of digital communication signals superimposed on the 4/20mA loop current. Alternatively, the MTL4544S acts as a current sink for a safe-area connection rather than driving a current into the load.

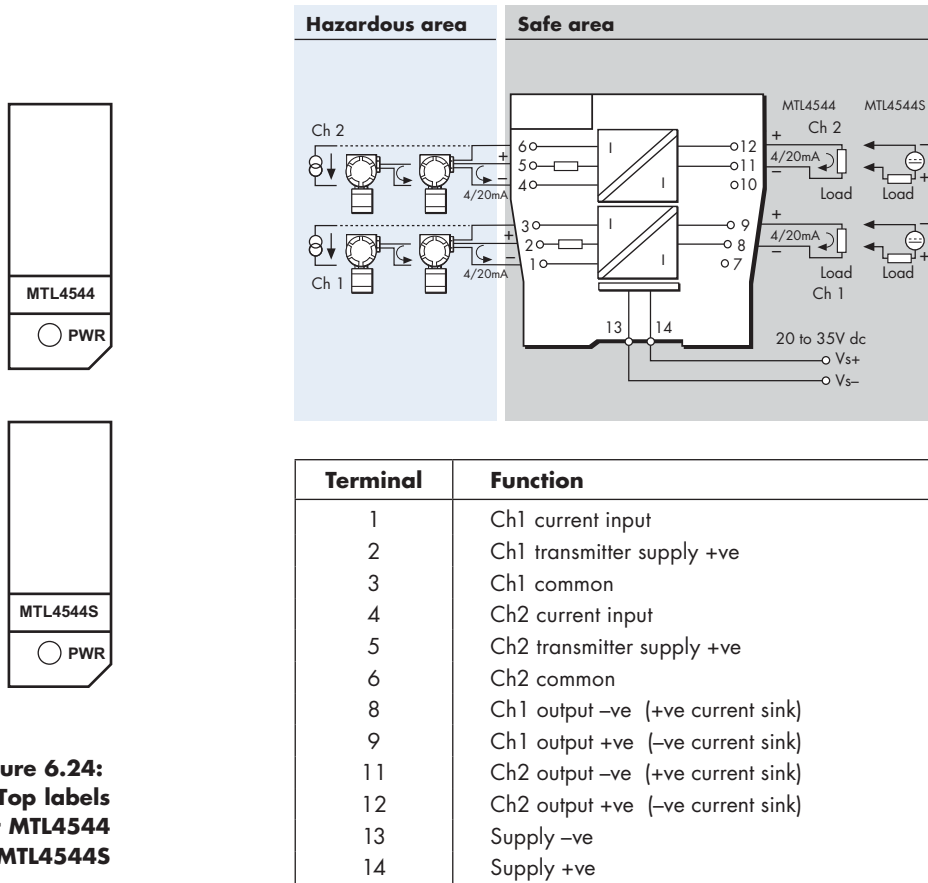
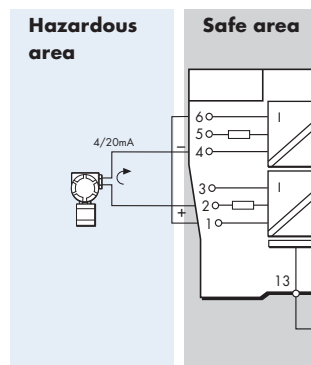

Figure 6.24:
Top labels
for MTL4544
& MTL4544S

The MTL4544 or MTL4544S can also be used to drive two safe-area loads from a single 2-wire transmitter (i.e. 1 in, 2 out) by interconnecting the input channels as shown in the diagram (right).

Note: In this mode the HART data is transferred via channel 1 output only.



6.4.5 MTL4544A/MTL4544AS - Repeater Power Supply

Two channel, 4/20mA, passive input for HART® transmitters

The MTL4544A provides inputs for separately powered 4/20mA transmitters and also allows bi-directional transmission of HART communication signals superimposed on the 4/20mA loop current. Alternatively, the MTL4544AS acts as a current sink for a safe-area connection rather than driving a current into the load.

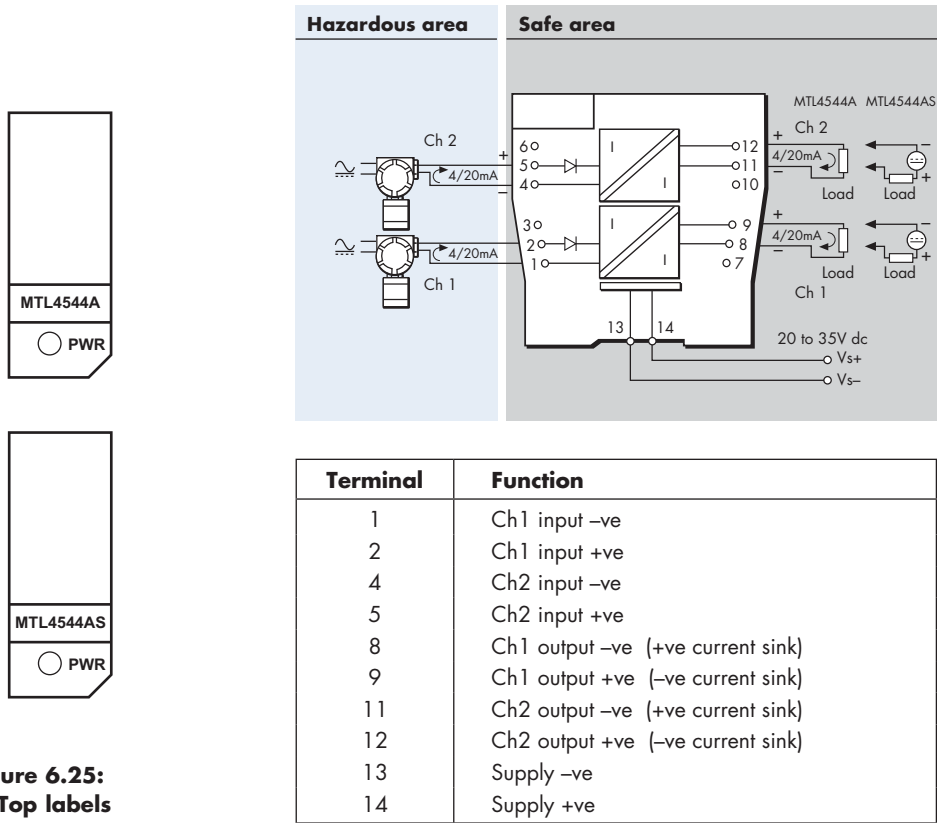

Figure 6.25:
Top labels
for MTL4544A
& MTL4544AS

6.4.6 MTL4544B - Repeater Power Supply

Two channel, 4/20mA, HART® for 2- or 3-wire transmitters

The MTL4544B provides fully-floating dc supplies for energising two conventional 2-wire or 3-wire 4/20mA or HART transmitters located in a hazardous area, and repeats the current in other circuits to drive two safe-area loads. For HART transmitters, the unit allows bi-directional transmission of digital communication signals superimposed on the 4/20mA loop current.

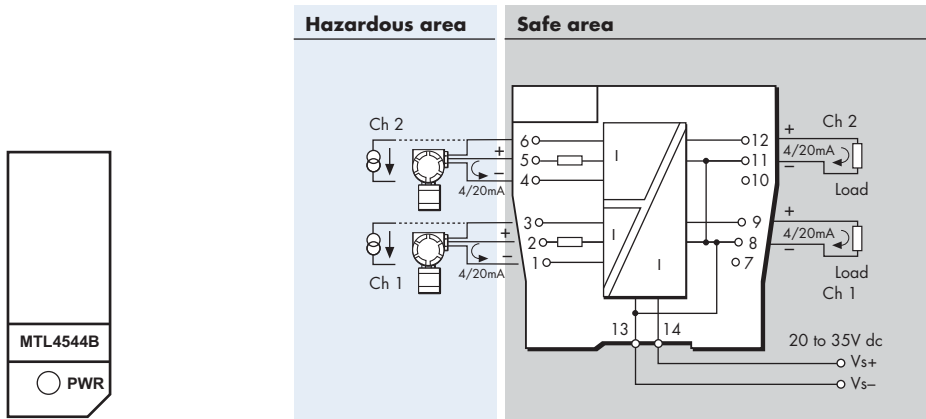

Figure 6.26:
Top label
for MTL4544B

Terminal	Function
1	Ch1 current input
2	Ch1 transmitter supply +ve
3	Ch1 common
4	Ch2 current input
5	Ch2 transmitter supply +ve
6	Ch2 common
8	Ch1 output -ve
9	Ch1 output +ve
11	Ch2 output -ve
12	Ch2 output +ve
13	Supply -ve
14	Supply +ve

Note: Safe area outputs are referenced to PSU -ve

6.4.7 MTL4544D - Repeater Power Supply

Single channel, 4/20mA, HART® for 2- or 3-wire transmitters, two outputs

The MTL4544D provides a fully-floating dc supply for energising a conventional 2- or 3-wire 4/20mA transmitter located in a hazardous area, and repeats the current in other circuits to drive two safe-area loads. For HART 2-wire transmitters, the unit allows bi-directional transmission of digital communication signals superimposed on the 4/20mA loop current.

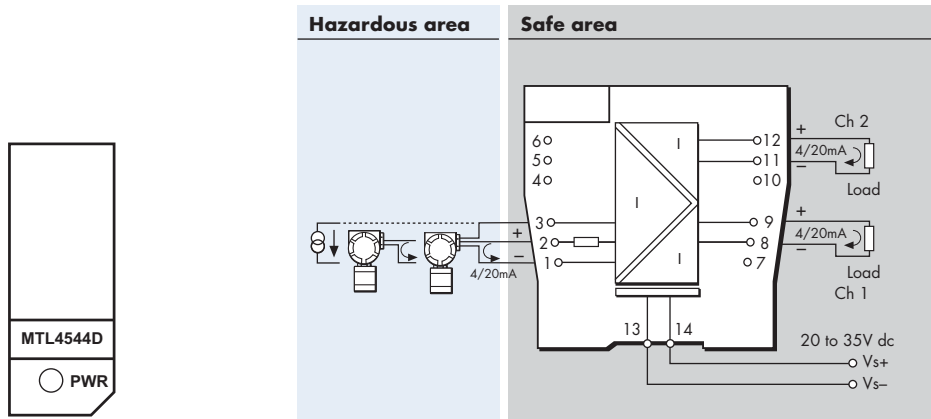

Figure 6.27:
Top label
for MTL4544D

Terminal	Function
1	Current input
2	Transmitter supply +ve
3	Common
8	Ch1 output -ve
9	Ch1 output +ve
11	Ch2 output -ve
12	Ch2 output +ve
13	Supply -ve
14	Supply +ve

6.5 Analogue Output modules

The analogue output (AO) modules accept 4/20mA floating signals from safe-area controllers to drive current/pressure converters (or any other load up to 800Ω) in a hazardous area.

6.5.1 MTL4546/MTL4546C/MTL4546Y - Isolating Driver

Single channel, 4/20mA, HART® for valve positioners with line-fault detection

The MTL4546 accepts a 4/20mA floating signal from a safe-area controller to drive a current/pressure converter (or any other load up to 800Ω) in a hazardous area. For HART valve positioners, the module also permits bi-directional transmission of digital communication signals so that the device can be interrogated either from the operator station or by a hand-held communicator. Process controllers with a readback facility can detect open or short circuits in the field wiring: if these occur, the current taken into the terminals drops to a preset level. The MTL4546C and MTL4546Y are identical to the MTL4546 except that they provide open circuit detection only (no short-circuit detection).

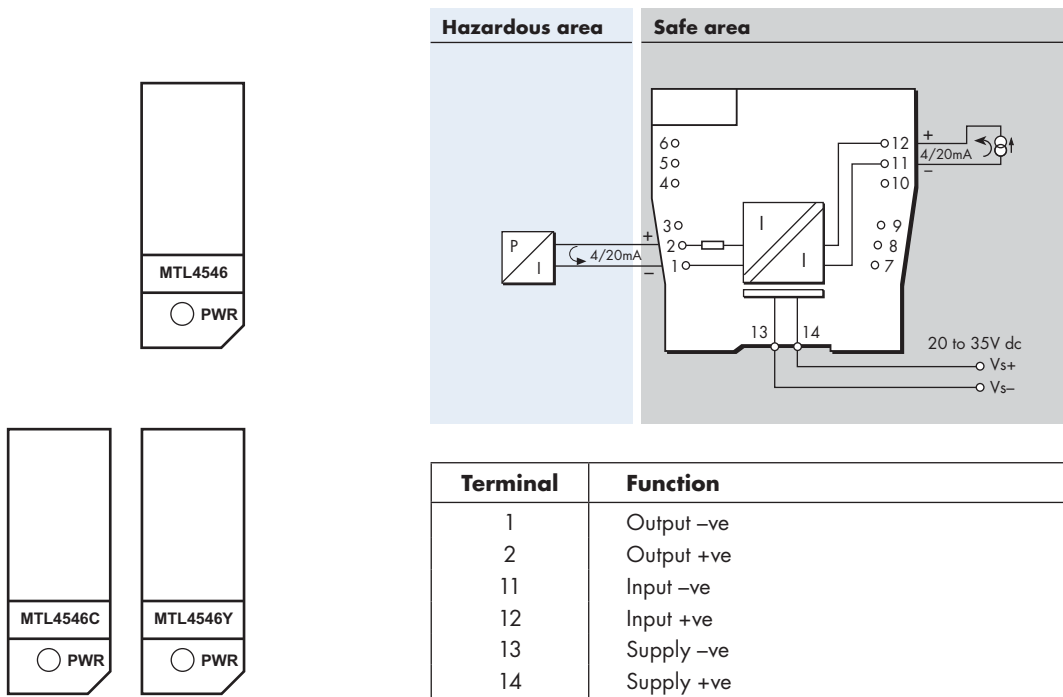

Figure 6.28:
Top labels
for MTL4546
MTL4546C &
MTL4546Y

6.5.2 MTL4549/MTL4549C/MTL4549Y - Isolating Driver

Two channel, 4/20mA, HART® for valve positioners with line-fault detection

The MTL4549 accepts 4/20mA floating signals from safe-area controllers to drive 2 current/pressure converters (or any other load up to 800Ω) in a hazardous area. For HART valve positioners, the module also permits bi-directional transmission of digital communication signals so that the device can be interrogated either from the operator station or by a hand-held communicator. Process controllers with a readback facility can detect open or short circuits in the field wiring: if these occur, the current taken into the terminals drops to a preset level. The MTL4549C and MTL4549Y are identical to the MTL4549 except that they provide open circuit detection only (no short-circuit detection).

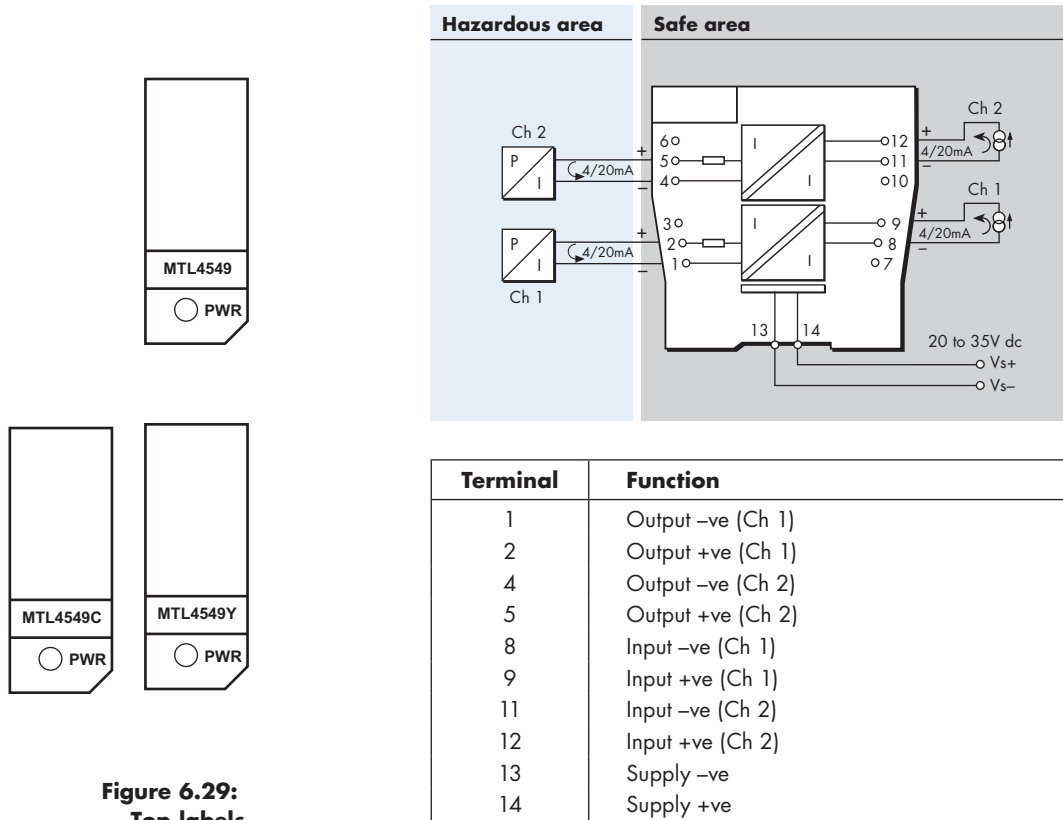

Figure 6.29:
Top labels
for MTL4549
MTL4549C &
MTL4549Y

6.6 Fire and Smoke Interface modules

Interfaces for use with conventional fire and smoke detectors located in hazardous areas.

6.6.1 MTL4561 - Fire and Smoke Detector Interface

Two channel

The MTL4561 is a loop-powered 2-channel interface for use with conventional fire and smoke detectors located in hazardous areas. In operation, the triggering of a detector causes a corresponding change in the safe-area current. The unit features reverse input polarity protection, while 'no-fail' earth fault detection on either line can be provided by connecting an earth leakage detector to terminal 3 and/or 6.

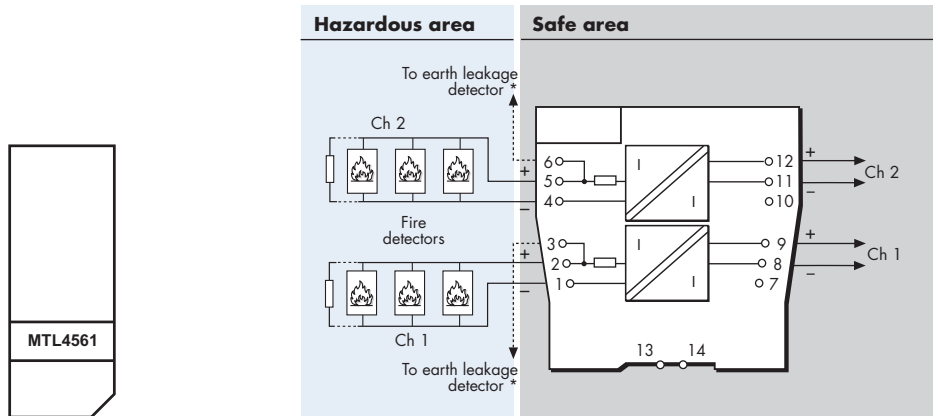

Figure 6.30:
Top label
for MTL4561

Terminal	Function
1	Output -ve (Ch 1)
2	Output +ve (Ch 1)
3	Earth leakage detection (Ch 1)
4	Output -ve (Ch 2)
5	Output +ve (Ch 2)
6	Earth leakage detection (Ch 2)
8	Input -ve (Ch 1)
9	Input +ve (Ch 1)
11	Input -ve (Ch 2)
12	Input +ve (Ch 2)

6.7 Temperature Input module

These modules accept inputs from low-level dc sources such as thermocouples or RTDs in hazardous areas and convert them into 4/20mA signals to drive safe area loads.

Early burnout detection (EBD)

When EBD is selected, the resistor of the thermocouple circuit is monitored and an alarm is raised when there is an increase of more than 50Ω. This enables preventative maintenance to be conducted on the field installation before the thermocouple actually breaks.

Configuration using PCS45/PCL45USB

Use PCS45 software, in conjunction with the PCL45USB serial link, to configure these modules. Instructions are contained within the software. See Section 6.9 on page 50 for further details.

6.7.1 MTL4575 - Temperature Converter

Single channel, THC or RTD input with alarm

The MTL4575 converts a low-level dc signal from a temperature sensor mounted in a hazardous area into a 4/20mA current for driving a safe-area load. Software selectable features include linearisation, ranging, monitoring, testing and tagging for all thermocouple types and 2, 3 or 4-wire RTDs. (For thermocouple applications the HAZ-CJC plug, on terminals 1–3, includes an integral CJC sensor). A single alarm output is provided and may be configured for high or low process alarm or to provide notice of early thermocouple failure.

continued on next page

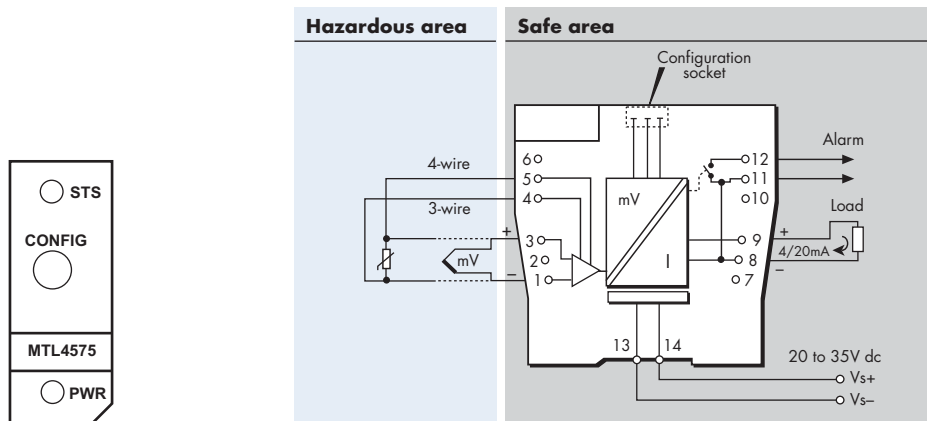

Figure 6.31:
Top label
for MTL4575

Terminal	Function
1	THC/mV/RTD input -ve
3	THC/mV/RTD input +ve
4	3-wire RTD input -ve
5	4-wire RTD input +ve
8	Output -ve
9	Output +ve
11	Output -ve/Alarm relay
12	Alarm relay
13	Supply -ve
14	Supply +ve

All MTL4575 modules are supplied with the following default configuration.

Input type	Type K thermocouple
Linearisation	enabled
Units	°C
CJ Compensation	enabled
Damping value	0 seconds
Smoothing value	0 seconds
Output zero	0°C
Output span	250°C
Tag and description fields	blank
Open circuit alarm	set high (upscale)
Transmitter failure alarm	set low (downscale)
CJ failure alarm	set low (downscale)
Line frequency	50Hz

Use PCS45 software, in conjunction with the PCL45USB serial link, to modify these default values.

Top label

Use the following LED information to understand the module status.

Status	PWR (green)	STS (yellow)
Power ON	ON	
Insufficient voltage or Power OFF	OFF	
Normal working	ON	
Device failure	FLASH	
Sensor failure/Error	FLASH	
Output relay ON (Trip)	ON	ON
Output relay OFF (Trip)	ON	OFF
Early burnout detection (EBD)	FAST FLASH	

6.7.2 MTL4576-RTD - Temperature Converter

Two channel, RTD/potentiometer input

The MTL4576-RTD converts signals from resistance temperature detectors (RTDs) mounted in a hazardous area, into 4/20mA currents for driving safe-area loads. The MTL4576-RTD is compatible with 2- and 3-wire RTD inputs.

Performance features, including input type and characterisation, ranging, monitoring, testing and tagging are selected using PCS45 software, which is loaded onto a personal computer and connected via the PCL45USB serial link - see Section 6.9.

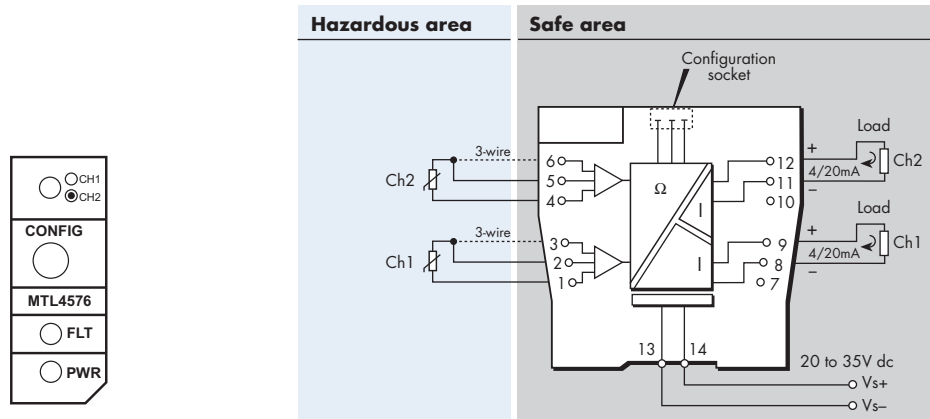

Figure 6.32:
Top label
for MTL4576

Terminal	Function
1	RTD input (Ch1)
2	RTD input (Ch1)
3	3-wire RTD input (Ch1)
4	RTD input (Ch2)
5	RTD input (Ch2)
6	3-wire RTD input (Ch2)
8	Output -ve (Ch1)
9	Output +ve (Ch1)
11	Output -ve (Ch2)
12	Output +ve (Ch2)
13	Supply -ve
14	Supply +ve

Top label

Use the following LED information to understand the module status.

Status	PWR (green)	FLT (red)	STS (yellow)
Power ON	ON		
Insufficient voltage or Power OFF	OFF		
Communication in progress	FLASH		
Normal working	ON	OFF	OFF
Device failure	ON	ON	
Channel 1 - Sensor failure/Error	ON	FLASH	OFF
Channel 2 - Sensor failure/Error	ON	FLASH	ON

6.7.3 MTL4576-THC - Temperature Converter

Two channel, mV/THC input

The MTL4576-THC converts low-level dc signals from temperature sensors mounted in a hazardous area, into 4/20mA currents for driving safe-area loads. The hazardous area connections include cold-junction compensation and do not need to be ordered separately.

Performance features, including linearisation for standard thermocouple types, ranging, monitoring, testing and tagging are selected using PCS45 software, which is loaded onto a personal computer and connected via the PCL45USB serial link - see Section 6.9.

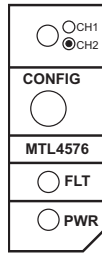
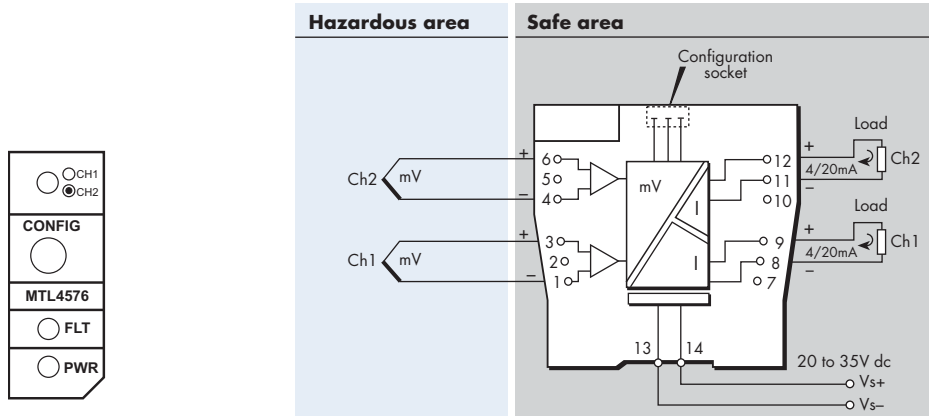

Figure 6.33:
Top label
for MTL4576

Terminal	Function
1	THC/mV (Ch1)
3	THC/mV (Ch1)
4	THC/mV (Ch2)
6	THC/mV (Ch2)
8	Output -ve (Ch1)
9	Output +ve (Ch1)
11	Output -ve (Ch2)
12	Output +ve (Ch2)
13	Supply -ve
14	Supply +ve

Top label

Use the following LED information to understand the module status.

Status	PWR (green)	FLT (red)	STS (yellow)
Power ON	ON		
Insufficient voltage or Power OFF	OFF		
Communication in progress	FLASH		
Normal working	ON	OFF	OFF
Device failure	ON	ON	
Channel 1 - Sensor failure/Error	ON	FLASH	OFF
Channel 2 - Sensor failure/Error	ON	FLASH	ON

6.8 General modules

These are general purpose modules that have applications associated with the MTL4500 range of modules.

6.8.1 MTL4599 - Dummy Isolator

The primary function of the MTL4599, is to provide termination and earthing facilities for unused cable cores from hazardous areas, that can occur, for example, if any MTL4500 Series module has been removed for maintenance purposes.

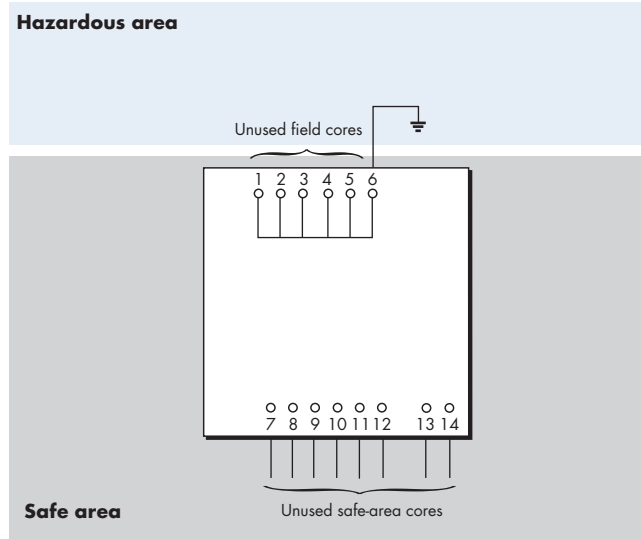

6.8.2 MTL4599N - General purpose feedthrough module

The feed-through termination module allows non-IS connections to the MTL4500 backplanes. The wires from the field are connected using screw terminals. Six terminals are provided for each contact of the multiway connector on the backplane. The terminals and cables conform to IS regulations so that non-IS and IS signals can be mixed on the same backplane.

Note: Must not be used with signals >50V or >0.25A

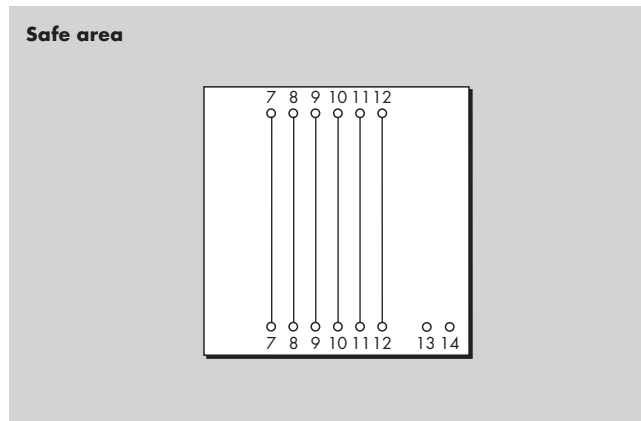

6.9 PCS45/PCL45USB configurator for MTL temperature converters

The PCS45/PCL45USB configurator allows MTL isolating temperature converters to be configured from a standard PC running a Microsoft® Windows® operating system. The configurator comprises PC software provided on a CD (PCS45), and an ATEX certified interfacing link (PCL45USB). Temperature converters can be configured from the safe area, while on-line, and the software allows configurations to be saved to disk and printed out when required.

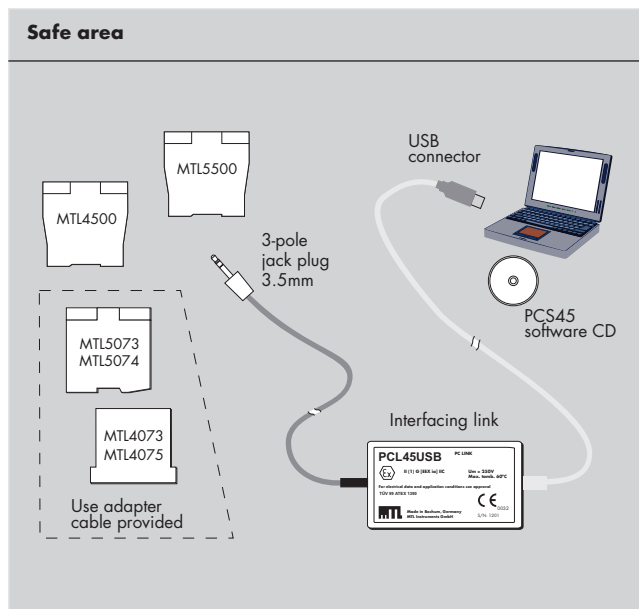

7 FAULT FINDING AND ROUTINE MAINTENANCE

WARNING: On removal, take care that a hazardous-area connector is not laid in a position in which it may inadvertently come into contact with the backplane or with components on the backplane.

7.1 Maintenance precautions

Most Codes of Practice for intrinsic safety permit live maintenance on intrinsically safe devices and systems, provided precautions are taken to preserve the integrity of the device or system. During live maintenance of MTL4500 modules, the hazardous-area connectors that plug into the tops of the modules are likely to be removed. Avoid leaving a hazardous-area connector in a position where it may inadvertently contact non-IS circuits that are nearby. Prevent this by providing some form of temporary mechanical method of securing the connector so that it cannot come into contact with the non-IS circuits:

- a) By plugging the connector into an MTL4599 dummy isolator
- b) By using a tiewrap to constrain the connector in a safe position.

7.2 Fault finding

When fault finding, carry out the following steps as far as is necessary:-

7.2.1

Check that one of the backplane power LEDs is ON.

7.2.2

If a power LED is not on, check the power supply fuse and if necessary, change it. Ratings are:-

- c) 4/8-way backplanes 1A (Spare fuse kit FUS1.0ATE5)
- d) 16-way backplanes 2A (Spare fuse kit FUS2.0ATE5)
- e) 24/32-way backplanes 4A (Spare fuse kit FUS4.0ATE5)

7.2.3

Check that all modules with power (PWR) LEDs are ON.

With the MTL4575 & MTL4576 models, a flashing LED indicates alarm or fault conditions, refer to section 8. Note: The LED may also flash during intermediate stages of configuration.

7.2.4

Exchange potentially faulty modules for working units as follows:-

- a) Unplug the hazardous-area connectors.
- b) Unplug the module from the backplane.
- c) Plug the replacement unit into the backplane.
- d) Replace the hazardous-area connectors.

7.2.5

Potentially faulty modules should be tested in workshop conditions, using the following procedure:-

- a) Connect a power supply to a spare CPS backplane (refer to sections 4.4.2 or 4.4.4).
- b) Plug the suspect module into any position on the backplane.
- c) Carry out the appropriate test procedure described in Section 8 for the particular module.

7.3 Routine maintenance

Check the general condition of the installation occasionally to make sure that no deterioration has occurred. Carry out the following at least once every two years and more frequently for particularly harsh environments:-

- a) Check that modules are of the types specified in the relevant documentation and that they are mounted in the correct positions on the associated backplanes.
- b) Check that modules and hazardous-area connectors are correctly and legibly tagged, that the connectors are plugged into the matching modules and that the tag details given comply with the relevant documentation.

- c) Check that modules and hazardous-area connectors are securely plugged into their matching sockets.
- d) Check that all connections to the backplane and to the hazardous-area connectors are properly made.
- e) Check that connecting cables to backplanes and to hazardous-area connectors are of the specified type and rating, are correctly routed and segregated (particularly in MTL enclosures), and are not frayed or otherwise damaged.
- f) Check that cable screens are properly earthed.

Note: It is strongly recommended that only the tests (described in Section 8) and routine maintenance (described here) should be undertaken by users. If a module is faulty, DO NOT attempt to make repairs or modifications as these may affect the intrinsic safety of the module. All faulty units should be returned to the MTL group company or representative from which they were purchased, for repair or replacement.

Any faulty backplanes supplied by MTL should also be similarly returned.

8 BENCH TESTING MODULES

The following methods have been devised to permit the user to perform simple module tests on the bench and confirm basic input to output operation. Field units that do not perform as described below, or modules that have 'unusual' operating behaviour, should be replaced and returned to MTL.

Consult individual module wiring diagrams for terminal connections.

Unless stated specifically, the module will require dc power, as if under normal operating conditions.

8.1 Digital Input (DI) modules

8.1.1 Modules: MTL4501-SR, MTL4510, MTL4510B, MTL4511, MTL4513, MTL4514, MTL4516, MTL4516C, MTL4517

Input Conditions

1. Connect the appropriate input test circuit to the channel under test (see **Figure 8.1** & **Table 8.1**).
2. For multi-channel modules with LFD, connect a 22kΩ resistor across the other channel input(s) to prevent the signalling of an unwanted open-circuit line fault.
3. Where appropriate test with phase reversal switch in both OFF and ON conditions.

Figure 8.1:
DI input
test circuit

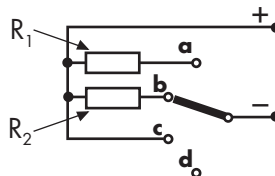

Table 8.1
Input test
conditions

Model	Resistor values	Switch - simulation conditions
MTL4501-SR	$R_1 = 10k\Omega$, $R_2 = 1k4\Omega$	a) Normal - field switch open b) Normal - field switch closed c) Line Fault - Test for short circuit d) Line Fault - Test for open circuit
MTL4510/4510B	$R_1 = 22k\Omega$, $R_2 = 680\Omega$	
MTL4511		
MTL4513		
MTL4514		
MTL4516		
MTL4516C		
MTL4517		

Output Results

1. For MTL4510 and MTL4510B modules refer to pages 13-15 of this manual.
2. The phase reversal switch will reverse the channel output conditions, but not the LFD.
3. With LFD disabled (OFF) its LED and contacts will remain as shown in shaded boxes below.

Table 8.2
Output test
results

Input switch positions	Channel contacts		LEDs		LFD contacts*	
	NC	NO	Status	LFD*	NC	NO
a	Closed	Open	OFF	OFF	Closed	Open
b	Open	Closed	ON	OFF	Closed	Open
c	Open	Closed	ON	ON	Open	Closed
d	Closed	Open	OFF	ON	Open	Closed

* If provided on the module.

8.2 Digital Output (DO) modules

Apply tests per channel.

8.2.1 Loop powered: - MTL4521 & MTL4525

Figure 8.2:
Loop powered
DO test circuit

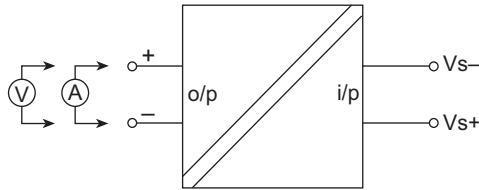

1. Connect a voltmeter between the + & - output terminals of the module, observing polarity.
2. Apply 24V between the supply terminals (Vs+, Vs-)
3. The voltmeter should indicate a value between 21.4 and 24 volts
4. Switch off the power to the module
5. Connect an ammeter between the + & - output terminals of the module, observing polarity
6. Apply 24V between the supply terminals (Vs+, Vs-)
7. The ammeter should indicate a value no greater than 48mA

8.2.2 Powered: - MTL4523, MTL4523R, MTL4523L, MTL4524 & MTL4524S

Figure 8.3:
Powered
DO test circuit

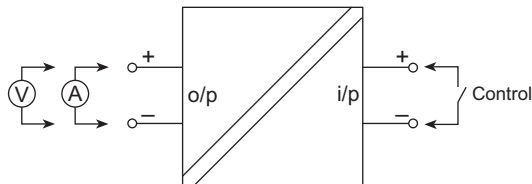

1. Connect a voltmeter between the + & - output terminals of the module, observing polarity
2. Apply 24V between the supply terminals Vs+, Vs-
3. Close the Control switch
4. The voltmeter should now indicate a value between 21.4 and 24 volts
5. Switch off the power to the module
6. Connect an ammeter between the + & - output terminals of the module, observing polarity
7. Apply 24V between the supply terminals (Vs+, Vs-)
8. Close the Control switch
9. The ammeter should indicate a value no greater than 48mA for any of the modules

8.2.3 Relay: - MTL4526

Figure 8.4:
DO test circuit
for relay type

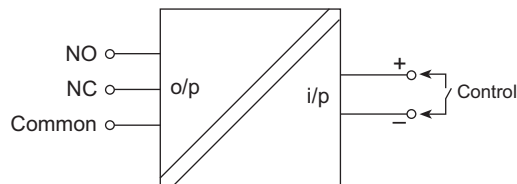

1. Set in 2-channel mode (SW1 - SW4 respectively to Off, On, On, On)
2. Confirm continuity between NC and Common
3. Apply 24V between the supply terminals Vs+, Vs-
4. Close the Control switch
5. Confirm continuity between NO and Common

8.3 Analogue Input (AI) Modules

All of these tests compare the *output* current with the *input* current (A1) over the normal range of operation, and measure the "error current" i.e. the difference - as indicated on A2. Apply these tests *per channel*, as appropriate.

Ammeter A2 must be capable of handling either polarity. If it is not an auto-ranging instrument, set it to a high range before switch on, then adjust sensitivity to obtain the required reading.

8.3.1 Modules: MTL4541, MTL4541B, MTL4541P, MTL4544, MTL4544B & MTL45544D

Figure 8.5:
AI test circuit #1

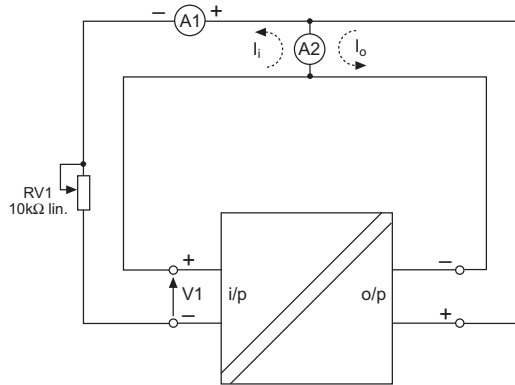

Output Measurements

Note: Do not connect a voltmeter in circuit to measure V1 until requested in Step 4 below, because current measurement A2 could be affected.

1. Adjust RV1 to vary the current (A1) through the range 4 to 20mA
2. The measured current imbalance (A2) over this range should not exceed $\pm 20\mu\text{A}$
3. Adjust RV1 for a 20mA reading on A1
4. The voltage V1, across the channel input, should typically be $>16.5\text{V}$.

8.3.2 Modules: MTL4541S, MTL4544S & MTL4561

Figure 8.6:
AI test circuit #2
"o/p sinking"

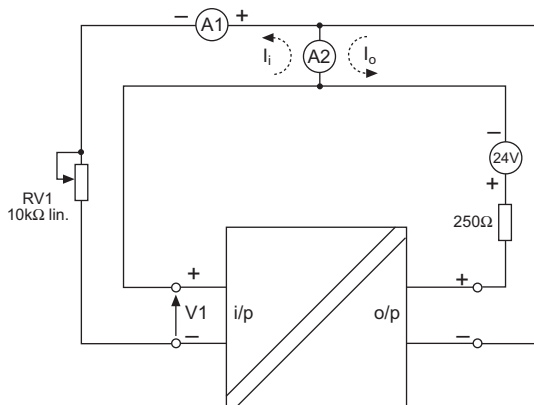

Output Measurements

Note: Do not connect a voltmeter in circuit to measure V1 until requested in Step 4 below, because current measurement A2 could be affected. Set A2 range to

1. Adjust RV1 to vary the current (A1) through the range 4 to 20mA.
2. The measured current imbalance (A2) over this range for the MTL4541S and the MTL4544S should not exceed $\pm 20\mu\text{A}$. For the MTL4561 the imbalance should not exceed $\pm 400\mu\text{A}$.
3. Adjust RV1 for a 20mA reading on A1
4. The voltage V1, across the channel input, should typically be $>16.5\text{V}$.

8.3.3 Modules: MTL4541A & MTL4544A

Figure 8.7:
AI test circuit #3
"active i/p"

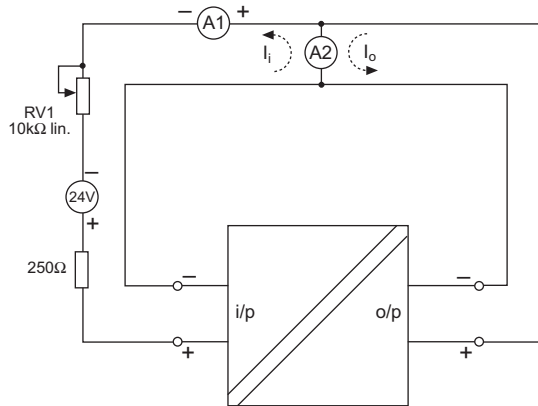

Output Measurements

1. Adjust RV1 to vary the current (A1) through the range 4 to 20mA.
2. The measured current imbalance (A2) over this range should not exceed $\pm 20\mu\text{A}$.

8.3.4 Modules: MTL4541AS & MTL4544AS

Figure 8.8:
AI test circuit #4
"active i/p -
o/p sinking"

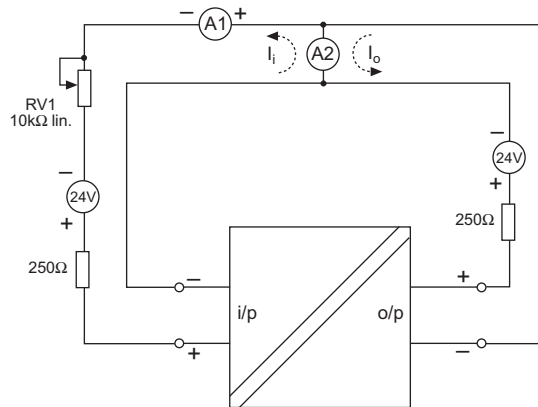

Output Measurements

1. Adjust RV1 to vary the current (A1) through the range 4 to 20mA.
2. The measured current imbalance (A2) over this range should not exceed $\pm 20\mu\text{A}$.

8.4 Analogue Output (AO) Modules

The test compares the output current with the input current over the normal range of operation.

8.4.1 Modules: All variants

Input Conditions

The chosen "load" resistor can be any value between 100 and 800 Ω .

Figure 8.9:
AO test circuit

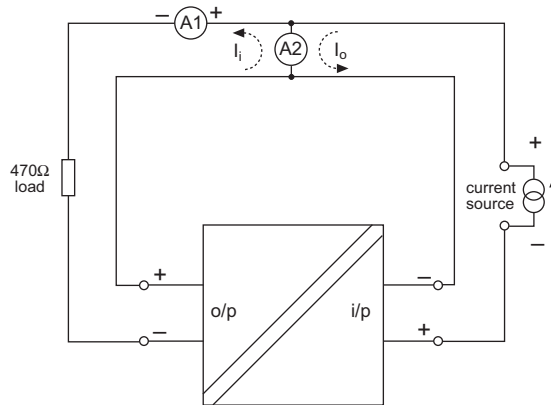

Output Measurements

1. Adjust the current source to vary the current (A1) through the range 4 to 20mA.
2. The measured current imbalance (A2) over this range should not exceed $\pm 20\mu\text{A}$.

8.5 Testing the functioning of other modules

Simple tests to verify their basic operation can be devised for other modules (e.g. temperature, pulse, vibration, etc). If any assistance is required for the testing of a particular module, please contact the technical support department at MTL for advice.

9 APPLICATIONS INVOLVING ZONE 2 AND/OR ZONE 22 HAZARDOUS AREAS

IMPORTANT: See page iv at the front of this manual for important additional information regarding the use of these products in countries governed by the ATEX Directive.

The European Community permits Category 3G equipment, such as the MTL4500 Series, to be installed in, or connected to, Zone 2 flammable atmospheres provided it meets the requirements of the ATEX Directive.

MTL4500 Category 3 products have been designed to meet, and carry approval markings for, Ex nL and/or Ex nA. Edition 5 of IEC 60079-11 has introduced the level of protection Ex ic, which is very similar to protection type Ex nL, defined in EN 60079-15, because they are both energy-limited concepts.

(Note: The IEC standards are considering Equipment Protection Level [EPL] marking but at this stage this will not be introduced on MTL products. The situation will be reviewed as the standard writing process becomes more definitive.)

In general, meeting the relevant requirements of the appropriate European (CENELEC) standards is considered the most appropriate method of demonstrating compliance with the ATEX directive. However, MTL often has its products approved by other national bodies, such as FM and CSA and, because national, European, and international standards are converging, it is generally possible to use other national approvals as supporting evidence for the ATEX Technical File.

In the context of this document, Zone 2 (Division 2) and Zone 22 hazardous areas are those that may become potentially explosive through the presence of flammable gases, vapours and dusts for periods of up to 10 hours per year. It is recommended that the current version of the standards is consulted for detailed information on the requirements applicable to the particular installation.

As a consequence of their IS approvals, MTL4500 products *may also be connected into Zone 22* hazardous areas. Consult individual module approvals for further details.

Unless otherwise specified, the following ambient conditions apply:

Ambient Temperature range	-20°C to +60°C
Pollution Degree 2	(See EN 61010-1)
Measurement Category II	(See EN 61010-1)

9.1 Enclosure

EN 60079-15 specifies the minimum required degree of protection to be IP54, but generally this is provided by the external enclosure in which the product is mounted.

The user must refer to the specific certificates relating to the products being installed within the hazardous area to check that all special conditions of safe use have been complied with.

THIS PAGE INTENTIONALLY LEFT BLANK

MTL Instruments Pty Limited

9 /12 Billabong Street
Stafford
Queensland 4053
Australia
Tel: + 61 1300 308 374 Fax: + 61 1300 308 463
E-mail: enquiries@mtlaus.com.au

Cooper Electric (Shanghai) Co.Ltd.

Room 2001, China Life Tower
16 Chao Yang Men Wai Street
Chao Yang District, Beijing
China 100020
Tel: + 86 10 5980 0288 Fax: + 86 10 8562 5725
E-mail: bjsales@mtl-inst.cn

MTL Instruments sarl

Les Carrés du Parc
10 rue des Rosiéristes
69410 Champagne au Mont d'Or
France
Tel: +33 (0)4 78 64 98 32 Fax: +33 (0)4 78 35 79 41
E-mail: info@mtl-inst.fr

MTL Instruments GmbH

An der Gumpgesbrücke 17
D-41564 Kaarst
Germany
Tel: +49 (0)2131 718930 Fax: +49 (0)2131 7189333
E-mail: info@mtl.de

MTL India

No. 36, Nehru Street
Off Old Mahabalipuram Road
Sholinganallur
Chennai - 600 119
India
Tel: + 91 (0)44 24501660/24501857 Fax: + 91 (0)44 24501463
E-mail: sales@mtlindia.com

MTL Italia srl

Via Cantù 11
I - 20092 Cinisello Balsamo MI
Italy
Tel: +39 (0)2 61802011 Fax: +39 (0)2 61294560
E-mail: info@mtl-inst.it

MTL Instruments KK

MT Building 3F
2-7-5 Shiba Daimon
Minato-ku Tokyo
Japan 105-0012
Tel: +81 (0)3 6430 3128 Fax: +81 (0)3 6430 3129
E-mail: sales@mtlkk.co.jp

Cooper Crouse-Hinds Korea

12F, Vision Tower
707-2 Yeoksam-dong, Gangnam-gu
Seoul 135-080
South Korea
Tel: +82 2 3484 6795 Fax: +82 2 3484 6778

MTL Instruments BV

MTL Instruments BV
Terheijdensweg 465
4825BK Breda
The Netherlands
Tel: +31(0)76 7505360 Fax: +31(0)76 7505370
E-mail: info@mtlbenelux.com

Cooper Crouse-Hinds Pte Ltd

No.2 Serangoon North Avenue 5
#06-01 Fu Yu Building
Singapore 554911
Tel: +65 6 487 7887 Fax: +65 6 487 7997
E-mail: sales@mtlsing.com.sg

MTL Instruments

Villa No. 4, Sector 2-17, Street 6
PO Box 53234,
Abu Dhabi, UAE
Tel: +971 2 446 6840 Fax: +971 2 446 6841
E-mail: mtlgulf@mtl-inst.com

Measurement Technology Limited

Great Marlings, Butterfield, Luton, Beds
England LU2 8DL
Tel: +44 (0)1582 723633 Fax: +44 (0)1582 422283
E-mail: enquiry@mtl-inst.com

MTL Incorporated

3413 N. Sam Houston Parkway W.
Suite 210
Houston TX 77086
USA
Tel: +1 281 571 8065 Fax: +1 281 571 8069
E-mail: csinfo@mtl-inst.com

